Service.

**Workshop Manual
Audi 100 1991 ▶**

Engine code	AAN				
Booklet 5 Cyl. F.I. engine (4-valve, turbo) Mechanics					

Edition 07.91

Service.

List of Workshop Manual Repair Groups

Audi 100 1991 ►

Engine code	AAN										
Booklet 5 Cyl. F.I. Engine (4-valve, Turbo), Mechanics Edition 07.91											

When filing a Technical Bulletin enter the Bulletin No. in the adjacent column. When using the Workshop Manual you can then see at a glance whether Technical Bulletins have been published in respect of the particular Repair Group in which you are looking.

Repair Group	Technical Bulletins									
00 Technical Data										
10 Removing and installing engine										
13 Crankshaft group										
15 Cylinder head, Valve gear										
17 Lubrication										
19 Cooling										
20 Fuel supply system										
21 Charging										
26 Exhaust system										

Technical Information should always be available to all foremen and mechanics, because their compliance with the instructions given is essential to ensure vehicle roadworthiness and safety. In addition, the normal safety precautions to be observed when working on motor vehicles are also applicable.

This Workshop Manual is only intended for use within the Volkswagen and Audi organisation, passing on to third parties is not permitted.
© 1991 Volkswagen AG

00	Technical Data	Page
	- Engine code	00-1
	- List of engines	00-2
10	Removing and Installing Engine	Page
	- Rules for cleanliness	10-1
	- Safety measures	10-1
	- Removing	10-2
	- Securing engine to repair stand	10-22
	- Installing	10-23
	- Tightening torques	10-25
13	Crankshaft Group	Page
	Dismantling and assembling engine	13-1
	- Removing and installing ribbed belt	13-1
	- Removing and installing toothed belt	13-6
	Dismantling and assembling cylinder block, crankshaft and flywheel	13-17
	- Measuring distance from lug to ignition firing point sender (-G4) and distance from flywheel to engine speed sender (-G28)	13-25
	- Crankshaft dimensions	13-27
	- Checking crankshaft radial clearance	13-28
	Dismantling and assembling pistons and conrods	13-29
	- Piston and cylinder dimensions	13-37
	- Checking conrod radial clearance	13-38
	Checking basic mechanical adjustment of engine	13-39
15	Cylinder Head, Valve Gear	Page
	Removing and installing cylinder head	15-1
	- Installing cylinder head	15-6
	- Checking compression pressure	15-7
	Servicing valve gear	15-9
	- Checking hydraulic bucket tappets	15-16
	- Renewing camshaft oil seal	15-18
	- Removing and installing camshafts	15-20
	- Reworking valve seats	15-24
	- Renewing valve guides	15-27
	- Renewing valve-stem oil seals (with cylinder head installed)	15-29
	- Renewing valve-stem oil seals (with cylinder head removed)	15-31
17	Lubrication	Page
	Removing and installing lubrication system components	17-1
	- Checking oil pressure switch and oil pressure	17-8
	- Checking oil pressure sender (-G10)	17-10
	- Removing and installing oil sump	17-12
	- Removing and installing oil pump	17-14
19	Cooling	Page
	Removing and installing cooling system components	19-1
	- Draining and filling coolant	19-10
	- Checking coolant system for leaks	19-14
	- Checking pressure relief valve in cap	19-14
	- Checking viscous fan	19-15
	Checking turbocharger thermostwitch -F98 and coolant pump	19-16

	Page
20 Fuel Supply System	20-1
Removing and installing fuel system components	20-1
- Rules for cleanliness when working on fuel supply/injection system	20-4
- Safety measures when working on fuel tank	20-5
- Removing and installing fuel gauge sender	20-6
- Removing and installing fuel pump	20-8
- Removing and installing fuel tank	20-11
Dismantling and assembling fuel pump	20-11
- Checking fuel pump	20-13
- Checking non-return valve of fuel pump	20-17
Servicing fuel tank ventilation with activated charcoal filter	20-19
Servicing throttle linkage	20-22
- Adjusting throttle cable	20-23
21 Turbocharging	Page
Removing and installing turbocharger components	21-1
- Rules for cleanliness when working on turbocharger	21-4
- Removing and installing turbocharger	21-5
- Checking turbocharger and waste gate	21-10
- Checking overrun cut-off valve with vacuum pump V.A.G 1390	21-13
Removing and installing intercooler components	21-14
- Removing and installing intercooler	21-16
26 Exhaust System	Page
Removing and installing exhaust system components	26-1
- Aligning exhaust system tension-free	26-7
- Checking exhaust system for leaks	26-8

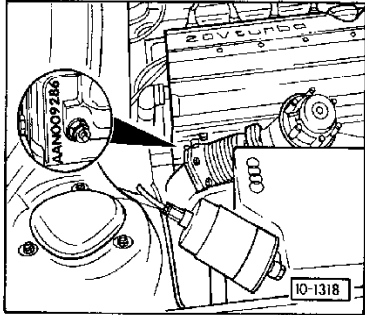

TECHNICAL DATA

◀ ENGINE CODE

Engine code and serial number are stamped on right-hand side at rear of cylinder head.

00-1

LIST OF ENGINES

<u>Engine code</u>	<u>AAN</u>	<u>Engine code</u>	<u>AAN</u>
<u>Engine characteristics</u>			
Manufactured	from 07/91 to -	Valve timing for 1 mm valve lift and 0 mm valve clearance:	
No. of cylinders	5	Inlet opens after TDC	3°
Displacement	ltr. 2.226	Inlet closes after BDC	25°
Output	kW/rpm 169/5900	Outlet opens before BDC	42°
Torque	Nm/rpm 350/1950	Outlet closes before TDC	9°
Bore	mm dia. 81.0	RON	at least 95
Stroke	mm 86.4	Fuel injection system	Motronic
Compression ratio	9.3	Exhaust gas recirculation	---
		Catalyst	2 x
		Lambda control	x
		Exhaust-gas turbocharger	x
		Vehicle especially tuned for:	Low pollutant exhaust

00-2

REMOVING AND INSTALLING ENGINE

RULES FOR CLEANLINESS

- o Thoroughly clean all unions and surrounding areas before disconnecting:
- o Place removed parts on clean surface and cover with film or paper. Do not use fluffy cloths!
- o Carefully cover or seal opened components if repairs cannot be carried out immediately.
- o Only install clean parts.
 - Only unpack replacement parts immediately prior to installation.
 - Do not use parts that have been stored loose (e.g. in tool boxes etc.).
- o When fuel system is open:
 - Do not work with compressed air if avoidable.
 - Do not move vehicle unless absolutely necessary.

SAFETY MEASURES

In order to avoid injuries to persons and/or destruction of ignition and fuel injection system, observe following:

- o Only disconnect and connect wires of Motronic ignition and fuel injection system, and measuring wires, with ignition switched off.

10-1

REMOVING:

- o Engine is removed upward without gearbox.
- o All cable ties removed or cut open during engine removal must be refitted in same location when installing.

Important!

If radio with anti-theft security coding is fitted, ascertain code number before disconnecting battery.

- Disconnect battery earthing strap.

Note:

On vehicles without fresh air filter or air conditioner, battery is located in plenum chamber on right. On vehicles with fresh air filter or air conditioner, it is installed under rear seat cushion.

10-2

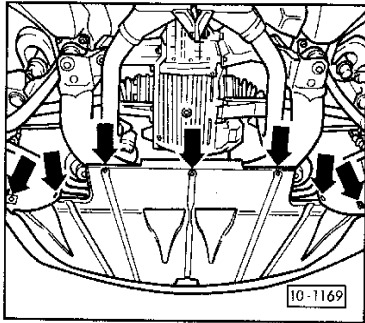

- ◀ - Remove noise insulation -arrows-. Disengage additional front retaining clips in centre of noise insulation.
- Remove front bumper - see Workshop Manual Audi 100 "General Body Repairs", Repair Group 63.
- Remove lock carrier plate - see Workshop Manual Audi 100 "General Body Repairs", Repair Group 50.
- Position oil catch pan VW 1306 under engine compartment.
- Open plug on coolant expansion tank.

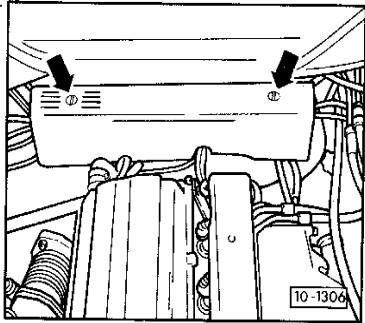

- ◀ - Turn quick fasteners -arrows- on connector cover on rear engine compartment bulkhead 90° to left and remove cover.

10-3

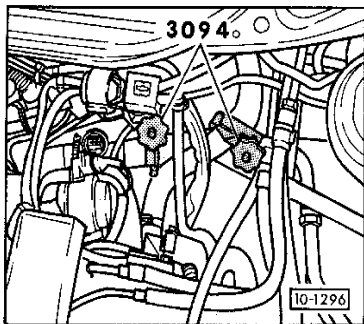

- ◀ - Plug water hoses to heater with special hose clamps 3094.

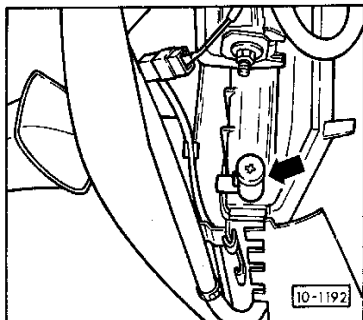

- ◀ - Drain coolant at cooler -arrow-, pushing auxiliary hose onto drain cock if necessary.

10-4

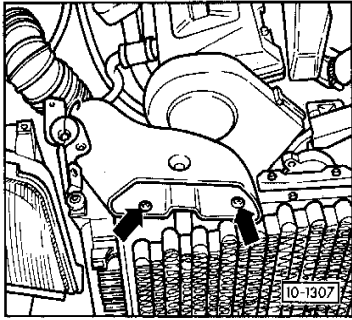

- ◀ - Unscrew right air duct at radiator -arrows- and remove.

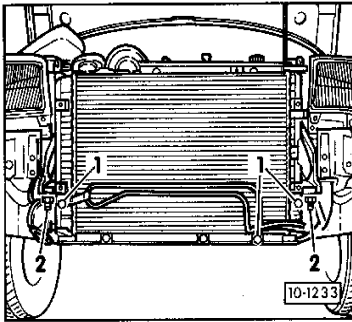

Vehicles without air conditioner

- ◀ - Remove oil cooler for hydraulic oil at radiator -1- and hang up on body (hoses remain connected).
- Disconnect water hoses at radiator.
- Remove radiator -2-.

10-5

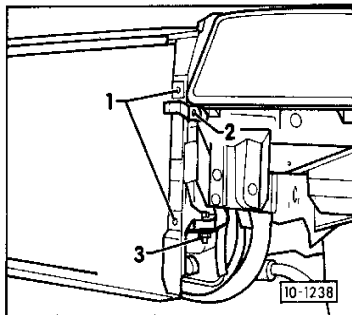

Vehicles with air conditioner

o Radiator remains installed.

- ◀ - Unscrew bracket for trim plate -2- on right-hand vehicle side.
- Unscrew right and left radiator attachment -3-.
- Unscrew left air guide at radiator -1-.

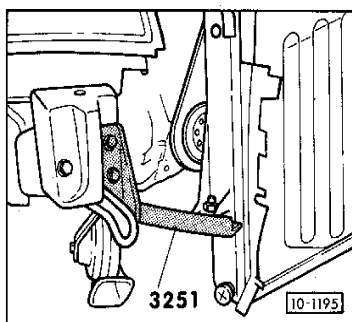

- ◀ - Attach support device 3251 to right-hand bumper bracket and swing radiator forward.

10-6

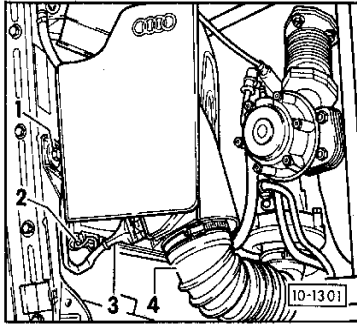

- ◀ - Disconnect air hose between air volume sensor and turbocharger -4- at air volume sensor.
- Pull off connector at air volume sensor -3-.
- Unscrew retaining bolt -1-.
- Loosen four spring clips -2-.
- Remove upper section of air cleaner housing and filter.
- Disconnect intake hose and take out lower section of air cleaner housing.

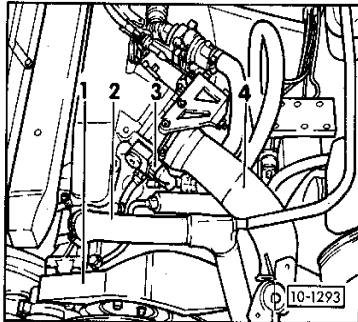

- ◀ - Disconnect upper hose to radiator -2- at radiator and coolant manifold and put aside. T-piece to expansion tank remains connected.
- Pull off cover -1- above ribbed belt.
- Pull off connector at throttle valve switch -3-.
- Remove air hose -4-.

10-7

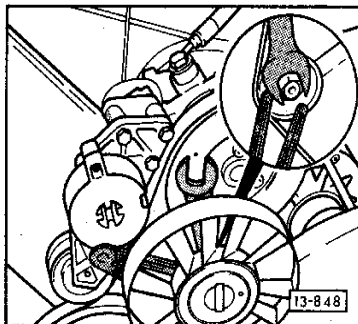

- ◀ - Unscrew viscous fan. Use spanner wrench 3212 to brace.
- Loosen bolts on belt pulley of vane pump for power steering.

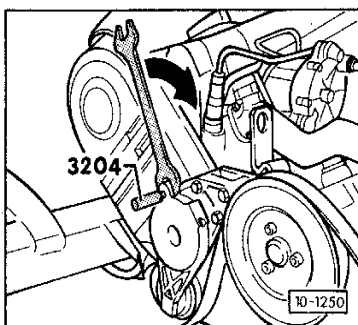

- ◀ - Slacken ribbed belt by turning tensioning device in direction of arrow with open-end spanner and inserting pin 3204 into hole.
- Remove ribbed belt.
- Remove belt pulley of vane pump for power steering.
- Take hose to vane pump out of bracket on left engine mount.
- Remove vane pump for power steering and set aside in engine compartment. Hoses remain connected.

10-8

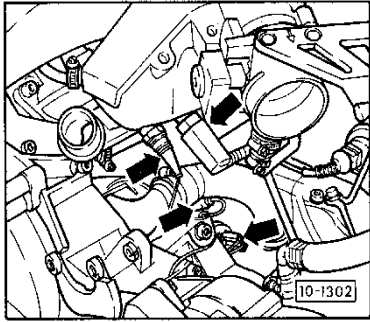

- ◀ - Pull off connectors -arrows- at:
 - o Thermoswitch - 2-pin
 - o Thermoswitch - 4-pin
 - o Oil pressure switch (white)
 - o Oil pressure gauge sender
- Pull off or unscrew wires from alternator and loosen cable clip.

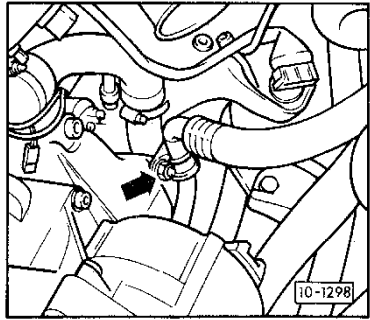

Vehicles with air conditioner:

- ◀ - Unscrew retaining clip for refrigerant and coolant pipe -arrow-.

Vehicles without air conditioner:

- Unscrew retaining tab for upper coolant pipe -arrow-.

10-9

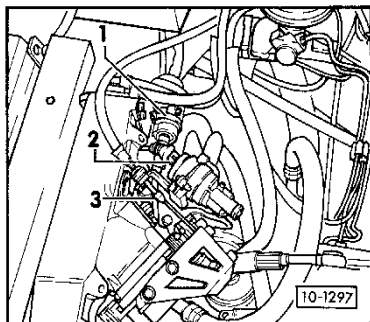

- ◀ - Detach throttle cable -3-.
- Pull off connector at idling speed stabilization valve -2-.
- Pull off connector and supply hose at solenoid valve for activated charcoal filter -1-.

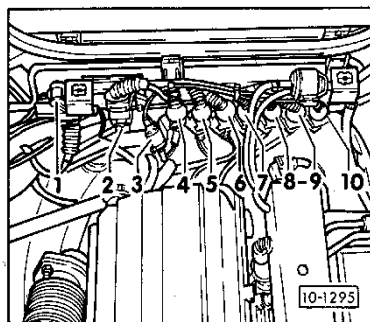

- ◀ - Mark connectors on rear engine compartment bulkhead and separate:
 - 1- Black plug (3-pin) to right ignition unit (2 pins connected in plug)
 - 2- Brown plug (3-pin) to left ignition unit
 - 3- Black round plug (single) to lambda probe
 - 4- Black plug (2-pin) to lambda probe
 - 5- White plug (3-pin) to ignition coils in cylinder head (lower plug section 3-pin)
 - 6- White plug (3-pin) to ignition coils in cylinder head (2 pins connected in lower plug section)
 - 7- Black plug (3-pin) to ignition firing point sender
 - 8- Grey plug to speed sender
 - 9- Brown plug to front knock sensor
 - 10- Blue plug to rear knock sensor

10-10

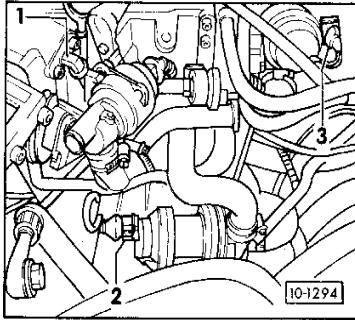

- ◀ - Unscrew pressure sensor -1- on throttle housing.
- Pull off connector to electric coolant pump -2- and to Hall sender -3-.
- Pull through wiring loom toward rear and expose.

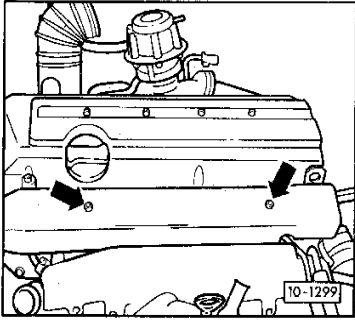

- ◀ - Unscrew injector cover.
- Pull connectors off injectors and expose wiring loom.
- Unscrew earthing wires.
 - o On upper intake manifold, wiring colour brown/red
 - o On rear intake manifold, wiring colour brown/white
- Pull connector off thermostat at back side of cylinder.
- Remove coolant hoses to heater on engine.

10-11

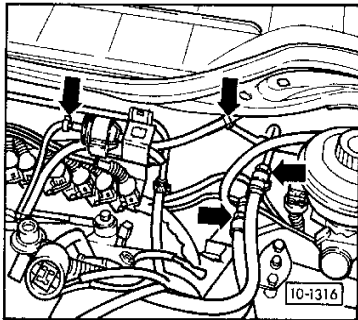

- ◀ - Separate fuel and vacuum pipes -arrows-.

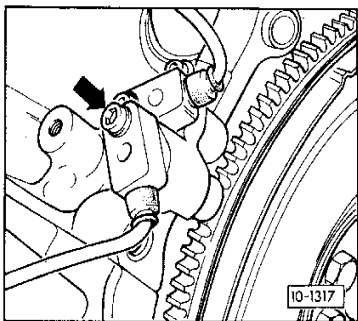

- ◀ - To avoid damage, unscrew speed sender above flywheel -arrow-.

10-12

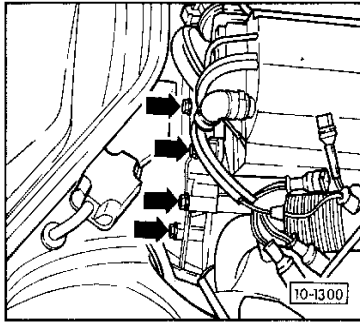

- ◀ - Unscrew bolts on engine/gearbox flange accessible from above -arrows-.
- One engine/gearbox bolt remains screwed in hand-tight.

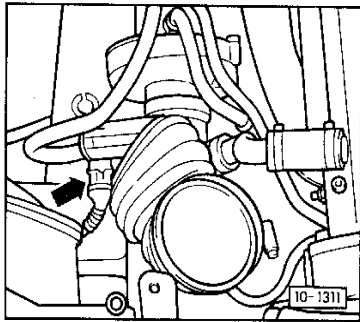

- ◀ - Pull connector of solenoid valve for charge pressure limiting -arrow-.

10-13

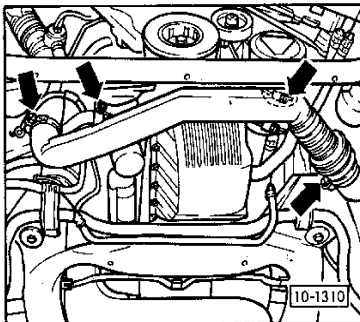

- ◀ - Remove pressure pipe between turbocharger and intercooler -arrows-.

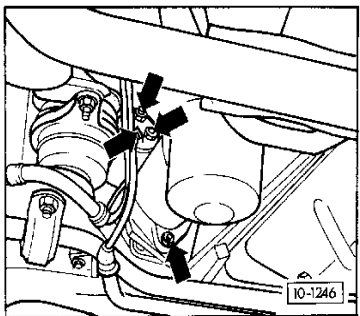

- ◀ - Remove starter -arrows-.

10-14

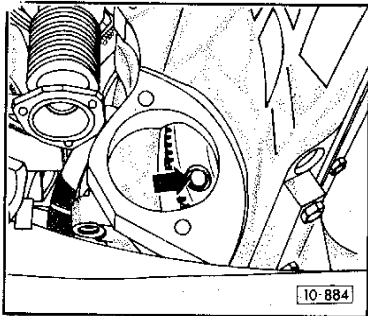

Vehicles with automatic gearbox:

- ◀ - Unscrew 3 bolts of torque converter in opening of removed starter (turn crankshaft 1/3 turn each time).

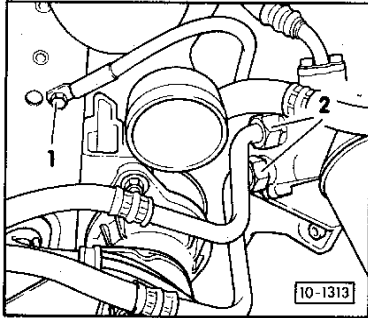

- ◀ - Unscrew earthing wire -1- from right longitudinal member.
- Mark oil pipes -2- and unscrew from oil filter flange, allowing oil to drip into catch pan.

10-15

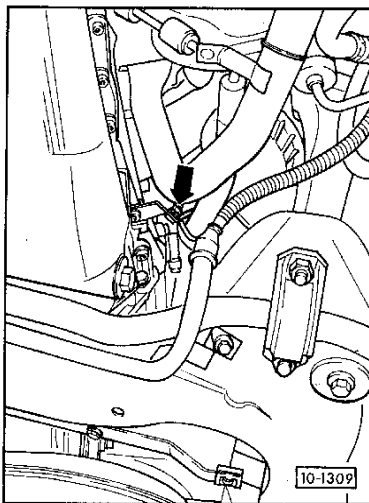

Vehicles with air conditioner:

Important!
 oRefrigerant circuit of air conditioner must not be opened.
 oRefrigerant pipes kink easily.

- ◀ - Unscrew bracket -arrow- for refrigerant hose at oil sump.

10-16

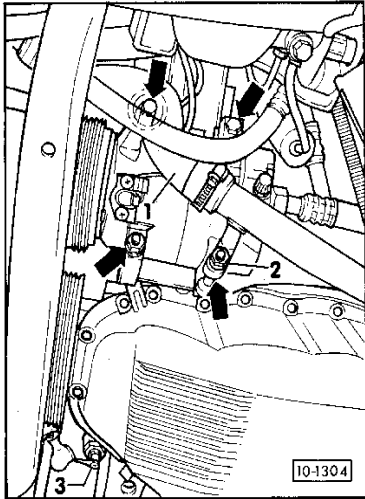

- ◀ - Unscrew and remove coolant pipe -3-.
- Unscrew A/C compressor -arrows- and hang up on side.

Note:

Refrigerant circuit can only be opened in workshops with specially trained personnel and necessary tools and workshop equipment.

- Detach wire -2- from oil temperature gauge sender.
- Remove lower coolant hose -1- to radiator.

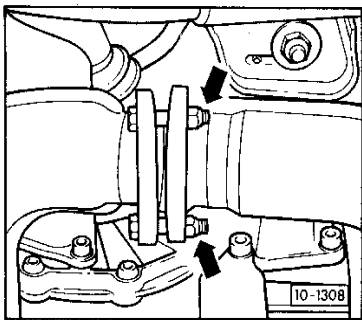

- ◀ - Remove front exhaust manifold: Unscrew bolts at bottom left and right -arrows-.

10-17

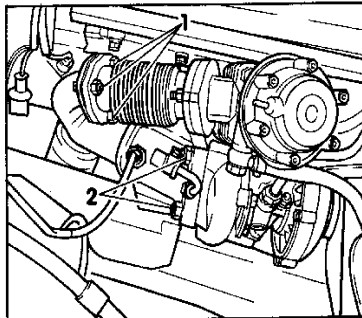

- ◀ - Unscrew three bolts -1- on corrugated pipe.
- Unscrew four nuts on turbocharger/exhaust down pipe flange -2-.

Note:

- o To remove lower rear nuts -2- on turbocharger/exhaust down pipe flange, flat ring spanner SW 15 must be bent to fit -arrow below in diagram-.
- o Other nuts on turbocharger/exhaust down pipe flange are spanner size 17.

- Take out exhaust down pipe downward.

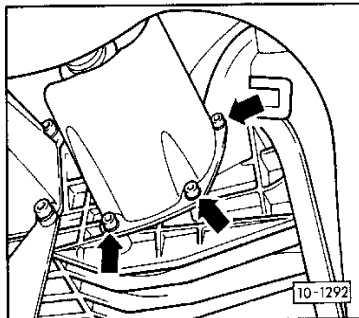
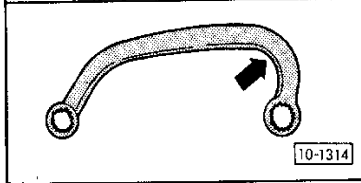

- ◀ - Remove cover for right drive shaft -arrows-.

10-18

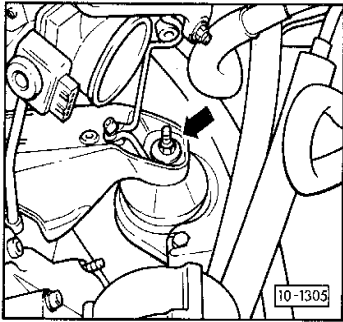

- ◀ - Unscrew nuts of left and right engine mounts -arrow-.

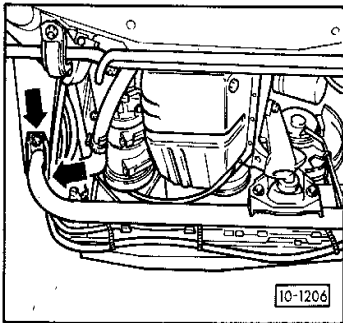

- Unscrew bolts on engine/gearbox flange accessible from below.
- ◀ - Remove traverse with torque arm. To do this, remove pressure reservoir bracket from left longitudinal member and torque arm from engine. Unscrew four bolts -arrows- and remove traverse.

10-19

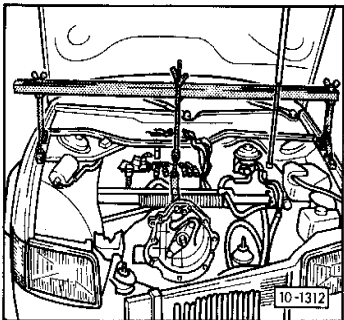

- ◀ - Position gearbox support 10-222 A on wing attachment lip.
- Hook gearbox mount 3147 into upper right bolt hole of gearbox bell housing (in diagram shown with engine removed).

Note:

Height of gearbox can be adjusted with wing nut of support hook.

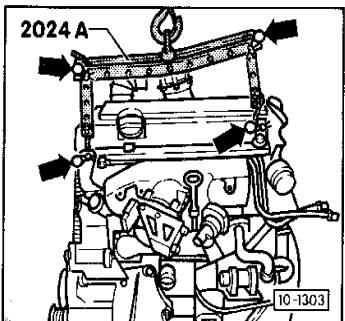

- ◀ - Hook engine support 2024 A to engine and to workshop crane 1202.

Note:

In order to balance engine's centre of gravity, bars for lifting hooks must be fitted as shown in diagram.

Important!

Hooks and pins of engine support must be secured with safety clips -arrows in diagram-.

10-20

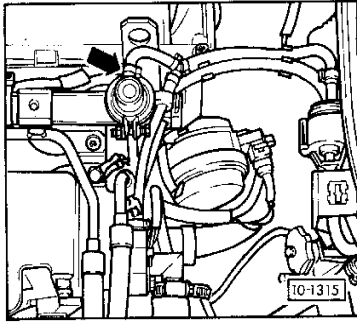

- ◀ - Ensure sufficient space between engine support and vacuum hose -arrow-. Remove hose if necessary.
- Lift engine with workshop crane using pins of engine mountings.
- Retighten wing nut on gearbox support 10-222 A accordingly.
- Upper engine/gearbox flange: Unscrew last bolt.
- Pull engine off gearbox and lift upward out of engine compartment.

Note:

Guide engine carefully when lifting out in order to avoid damaging clutch, body and radiator.

Vehicles with automatic gearbox:

- After removing engine, secure torque converter in gearbox from falling out.

10-21

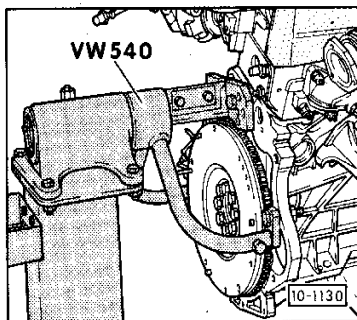

SECURING ENGINE TO REPAIR STAND

- ◀ Secure engine to repair stand with engine and gearbox bracket VW 540 in order to carry out repairs.

Note:

Do not measure cylinder bores (Repair Group 13) with engine mounted on repair stand.

10-22

INSTALLING:

Install engine in reverse order and observe following points.

- o Check whether locating sleeves for centring engine/gearbox are installed in cylinder block; fit sleeves if necessary.
- o Always renew self-locking nuts.
- o Always renew seals.
- o If necessary, check centring of clutch drive plate.
- o Clean tothing of gearbox input shaft. Thinly coat tothing and clutch release bearing with G 000 100. Do not grease guide sleeve for release bearing.
- o Make sure that support tab of coolant pipe is not pinched between engine and gearbox while pushing these together.
- o Install engine mounting torque-free by aligning engine with shaking movements before tightening engine mounting.
- o Install coolant pipe, retaining clip for refrigerant pipe and A/C compressor together.

10-23

- o When tightening exhaust down pipe on turbocharger, ensure freedom of movement between exhaust down pipe and subframe.
- o Align exhaust system tension-free - Repair Group 26.
- o Adjust throttle cable - see Repair Group 20.
- o Do not reuse drained coolant. Fill coolant - see Repair Group 19.
- o Check oil level before starting engine.

Note:

- o Secure all cable ties taken out during removal at same location during installation.
- o Secure wiring exposed during removal tension-free at same location during installation.

10-24

TIGHTENING TORQUES

Bolts/nuts - general	M6	10 Nm
	M8	20 Nm
	M10	45 Nm
	M12	60 Nm

Exceptions:

Exhaust down pipe to turbocharger	30 Nm
Exhaust down pipe to corrugated pipe	25 Nm
Exhaust down pipe to catalyst	25 Nm
Catalyst to gearbox support	25 Nm
A/C compressor to bracket	25 Nm
Torque converter to drive plate	60 Nm
Viscous fan to carrier	20 Nm

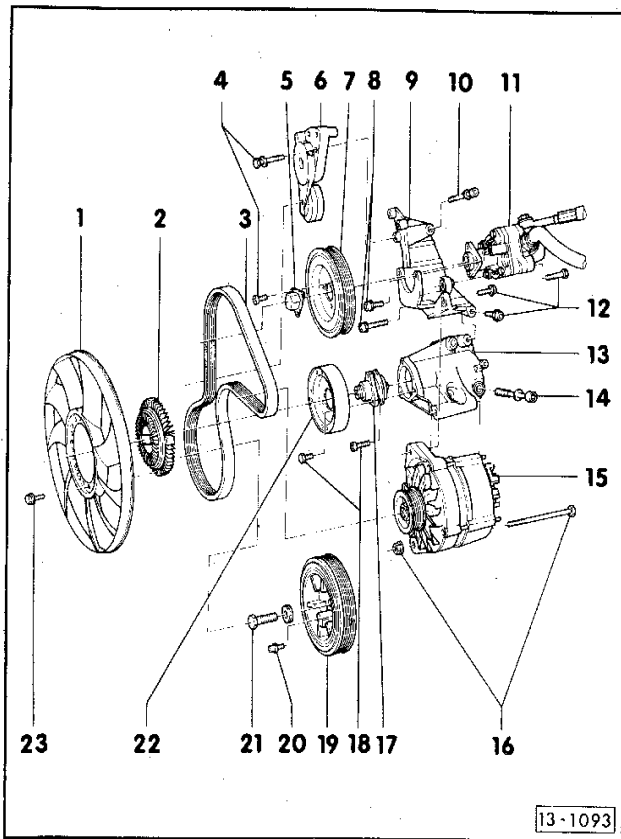

13-1093

DISMANTLING AND ASSEMBLING ENGINE

REMOVING AND INSTALLING RIBBED BELT

Note:

Exploded view shows version without air conditioner.

- 1- **Fan**
 - o "FRONT" marking on outer ring must point in direction of travel
- 2- **Viscous clutch**
 - o Switch-on temperature: 76 ± 4 °C
 - o Ambient temperature at viscous clutch
 - o Checking - see Repair Group 19
 - o Removing - see "Removing ribbed belt" - Page 13-4
 - o Tightening torque of viscous clutch -2- to bearing -17-: 20 Nm
 - o Reverse-threaded
- 3- **Ribbed belt**
 - o Mark direction of travel before removing with chalk or felt pen and observe when installing
 - o Opposite direction of travel on used belt leads to its destruction

13-1

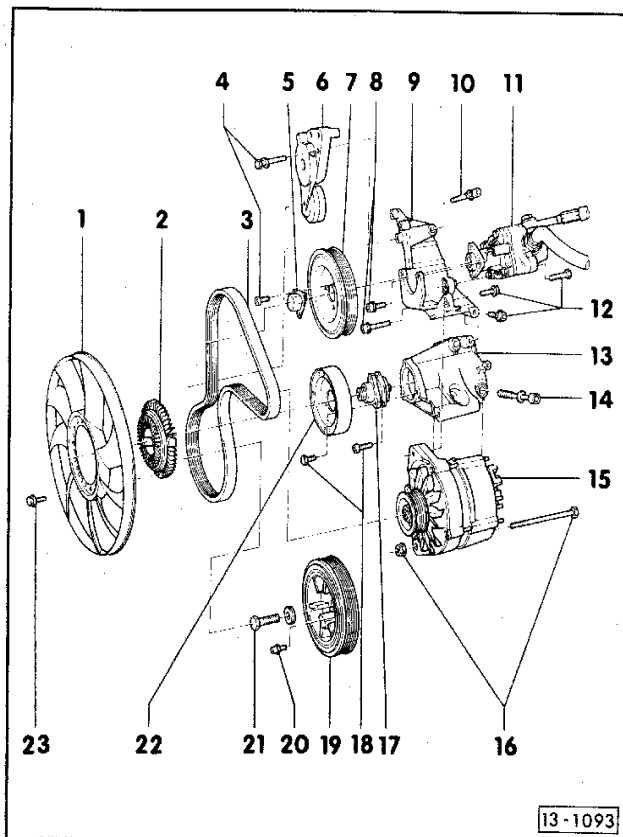

13-1093

- 4- 20 Nm
- 5- **Hexagon flange**
 - o For turning engine by hand with open-end spanner SW 32
- 6- **Belt tensioner**
 - o To slacken ribbed belt, swivel belt tensioner toward left vehicle side with open-end spanner and secure with pin 3204
- 7- **Belt pulley for hydraulic pump**
- 8- 20 Nm
- 9- **Hydraulic pump bracket**
- 10- 20 Nm
- 11- **Hydraulic pump**
 - o For power steering
- 12- 20 Nm
- 13- **Alternator bracket**
- 14- 45 Nm
- 15- **Alternator**
- 16- 45 Nm

13-2

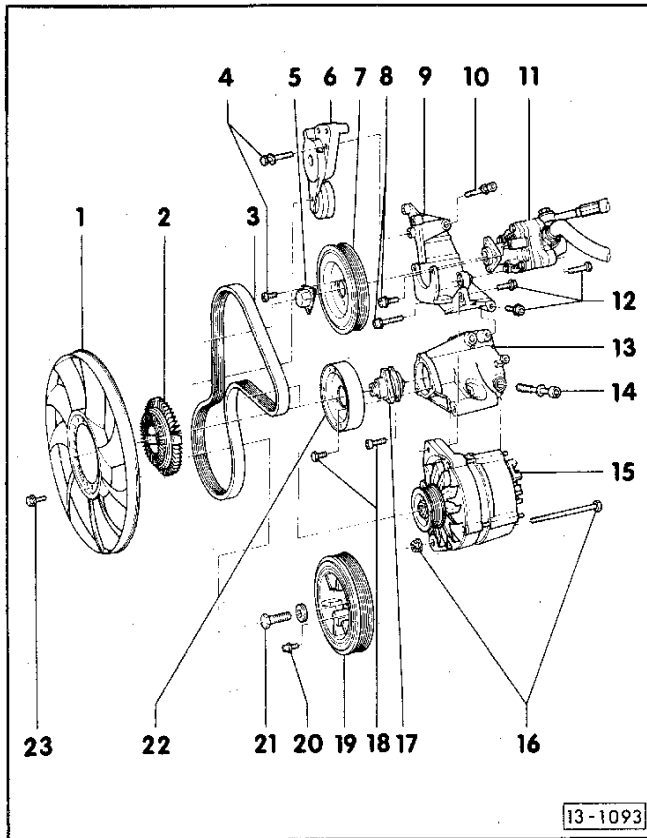

- 17- Viscous clutch bearing
 - o Check for ease of movement
- 18- 20 Nm
- 19- Vibration damper with belt pulley
 - o Fitting on toothed belt pulley of crankshaft only possible in one position; holes offset
 - o Removing and installing ribbed belt - Page 13-1
- 20- 25 Nm
- 21- Central bolt
 - o Tightening torque - see "Removing and installing vibration damper" - Page 13-9
- 22- Belt pulley
 - o For viscous clutch
 - o "VORNE" marking points in direction of vehicle travel
- 23- 10 Nm

13-3

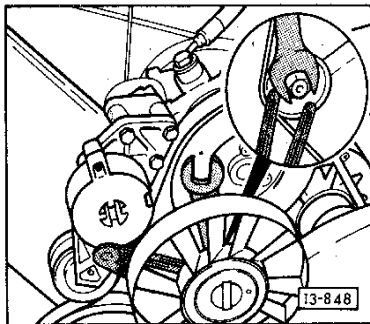

Removing:

Note:

Mark direction of travel of ribbed belt with chalk or felt pen before removing and observe when installing. Opposite direction of travel with used belt leads to its destruction.

- Removing lock carrier plate - see Workshop Manual Audi 100 "General Body Repairs", Repair Group 50
- ◀ - Unscrew viscous fan (use spanner wrench 3212 to brace)
- Lay viscous fan in fan frame.

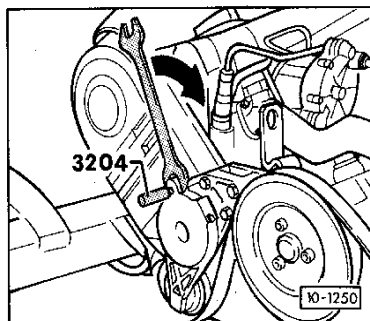

- If necessary, unclip lower wiring loom from fan frame.
- Unscrew fan frame from radiator and pull out upward together with viscous fan.
- ◀ - Slacken ribbed belt by swinging tensioner in direction of arrow and inserting pin 3204 into holes.
- Remove ribbed belt.

13-4

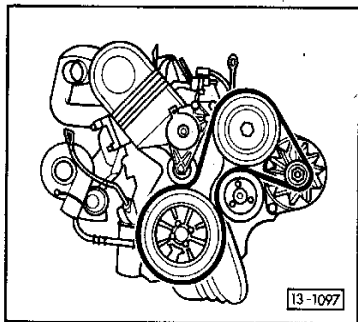

Installing:

- ◀ o Routing of ribbed belt on vehicles without air conditioner.

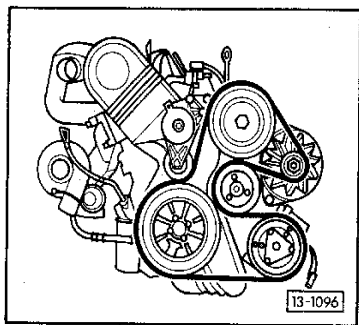

- ◀ o Routing of ribbed belt on vehicles with air conditioner.

13-5

REMOVING AND INSTALLING TOOTHED BELT

Note:

- o Always renew gaskets and sealing rings.
- o Removing and installing cylinder head - see Repair Group 15

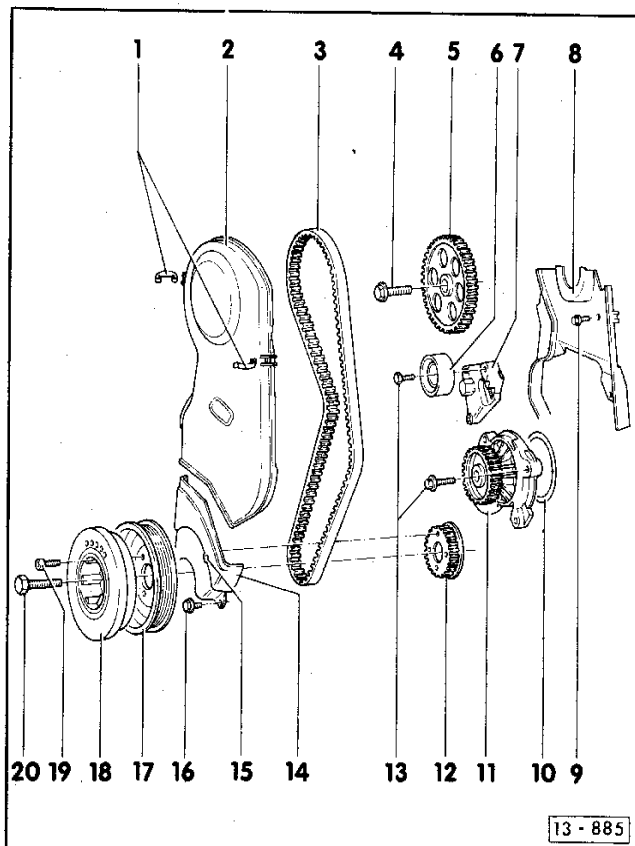

- 1- Clip
- 2- Upper toothed belt guard
- 3- Toothed belt
 - o Removing and installing, tensioning - Page 13-10
 - o Mark direction of travel of toothed belt before removing
 - o Only tension toothed belt with engine cold
 - o Toothed belt must not be kinked
- 4- 65 Nm
 - o Use brace 3036 to loosen and tighten
- 5- Camshaft sprocket
 - o Removing and installing - see "Removing and installing toothed belt" - Page 13-10

13-6

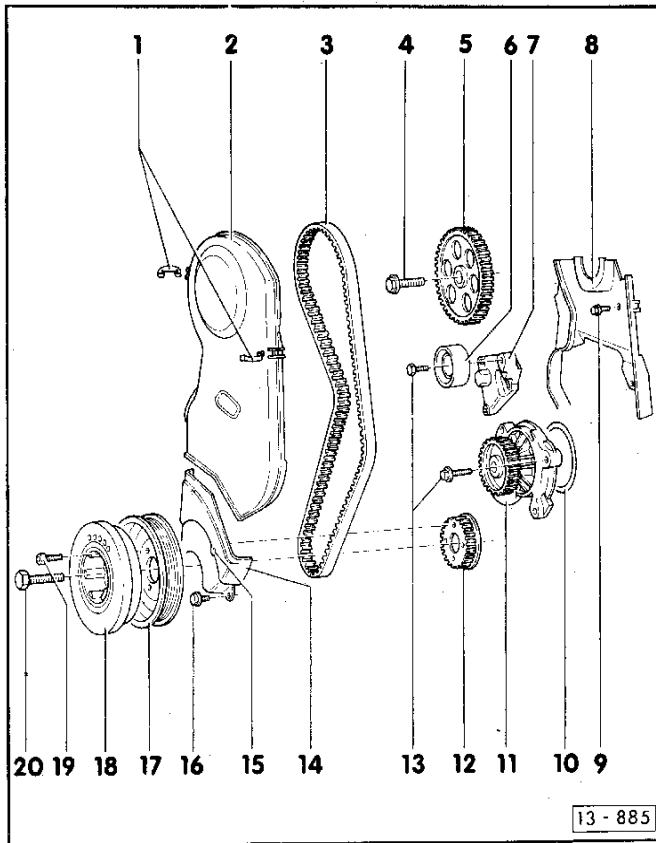

- 6- Idler pulley
- 7- Tensioner
 - o Tension toothed belt - see "Removing and installing toothed belt" - Page 13-10
 - o Only tension toothed belt with engine cold
- 8- Rear toothed belt guard
- 9- 10 Nm
- 10- O-ring
 - o Renew
- 11- Coolant pump
 - o Check shaft for ease of movement
 - o Renew coolant pump if damaged or leaky
 - o Removing and installing - see Repair Group 19
- 12- Toothed belt pulley for crankshaft
- 13- 20 Nm
- 14- Lower toothed belt guard
- 15- TDC marking
- 16- 10 Nm

13-7

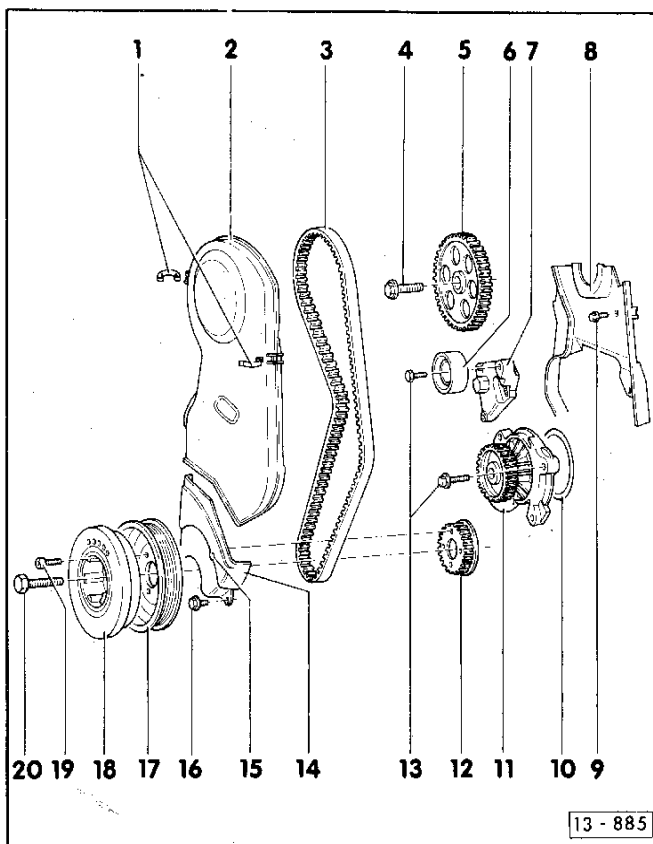

- 17- Belt pulley
 - o Watch fixing when mounting on toothed belt pulley
 - o Removing and installing ribbed belt - Page 13-1
- 18- Vibration damper
 - o Mounting of vibration damper and belt pulley on toothed belt pulley of crankshaft only possible in one position - holes offset
 - o Removing and installing - Fig. 1, Page 13-9
- 19- 25 Nm
- 20- Central bolt
 - o Tightening torque - see "Removing and installing vibration damper" - Fig. 1, Page 13-9

13-8

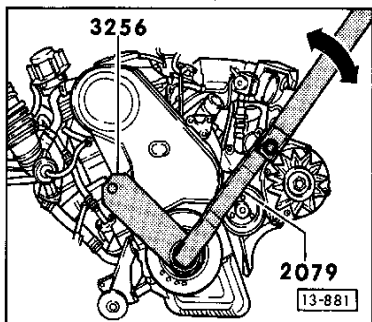

◀ Fig. 1 Removing and installing vibration damper

- o Tightening torque with spanner for vibration damper 2079: 350 Nm.
- o Tightening torque without spanner for vibration damper 2079: 450 Nm
- o Use brace 3256.
- o Coat threads and contact surfaces of bolt head with sealing paste AMV 188 001 02.

Note:

Spanner for vibration damper must align with torque wrench.

13-9

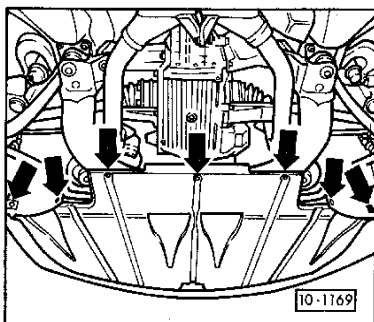

Removing:

- o Engine installed.

Note:

- o Mark direction of travel of toothed belt with chalk or felt pen before removing.
- o Toothed belt must not be kinked.

- ◀ - Remove noise insulation -arrows-. Disengage additional front retaining lug in centre of noise insulation.
- Remove front bumper - see Workshop Manual Audi 100 "General Body Repairs", Repair Group 63.
- Remove lock carrier plate - see Workshop Manual Audi 100 "General Body Repairs", Repair Group 50.
- ◀ - Unscrew bracket for trim plate -2- from right vehicle side.
- Unscrew right and left radiator bolts -3-.
- Unscrew left air guide from radiator -1-.
- Remove upper air duct from radiator.

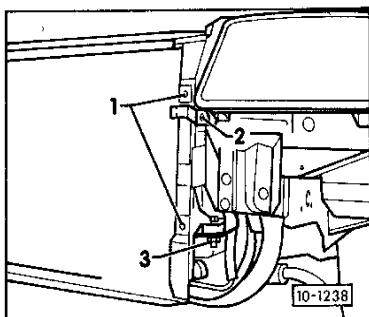

13-10

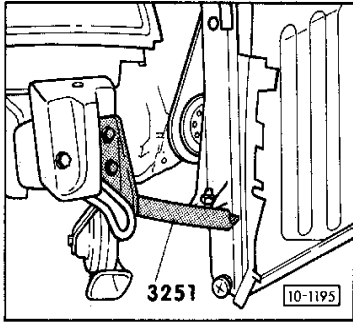

- ◀ - Attach support 3251 to right bumper mount and swing radiator forward.

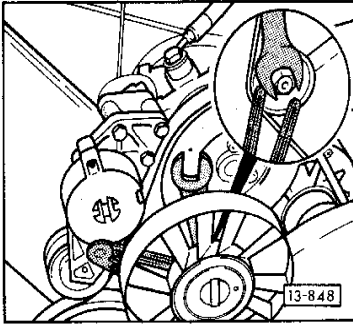

- ◀ - Unscrew viscous fan (use spanner wrench 3212 to brace).
- Slacken ribbed belt and remove - Page 13-4.
- Unscrew tensioner for ribbed belt.
- Remove upper toothed belt guard.

13-11

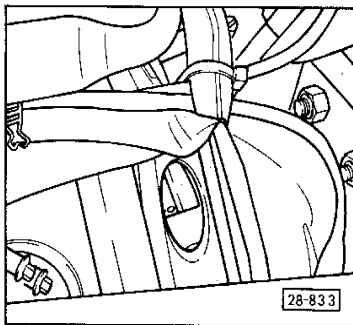

Note:
Instead of "0", notch can also be made in flywheel as TDC marking.

- ◀ - Turn crankshaft to TDC, cylinder 1. TDC marking must be positioned below edge in inspection hole ...

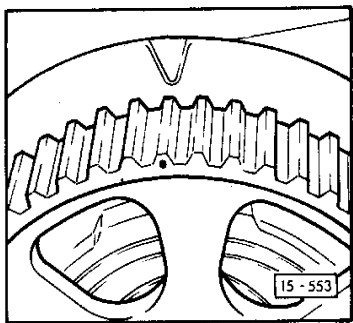

- ◀ - ... and markings on camshaft sprocket and cylinder head cover must align.
- If markings on camshaft are offset by half rotation, turn crankshaft additional rotation.

Note:
Hexagon flange (SW 32) is provided on hydraulic pump for turning engine by hand.

13-12

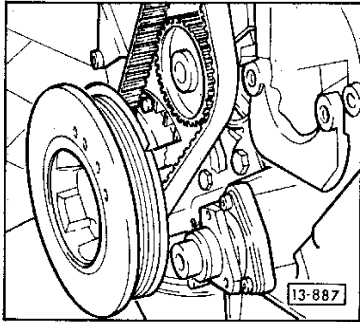

Engine removed:

- ◀ - Align notch on belt pulley with adjustment edge on oil pump housing.

Note:

There is also an adjustment marking located on lower toothed belt guard (removed in diagram)
 - Page 13-7, item 15.

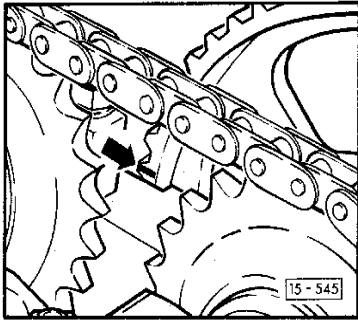

Cylinder head cover removed:

- ◀ - Marking on camshaft sprocket must align with upper edge of cylinder head.

13-13

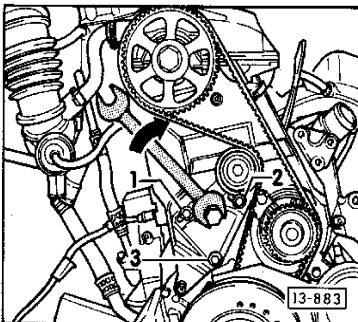

- ◀ - Loosen bolts of tensioner -1 ... 3-.
- Remove vibration damper - Fig. 1, Page 13-9.
- Remove lower toothed belt guard.
- Take off toothed belt with vibration damper.

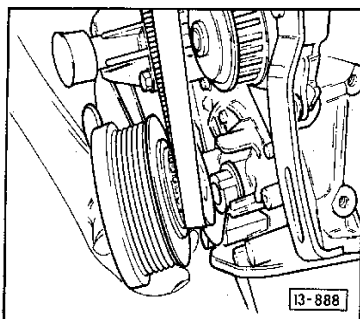

Installing:

- ◀ - Lay toothed belt on belt pulley of crankshaft and secure vibration damper to crankshaft - Fig. 1, Page 13-9.
- At same time, fit lower toothed belt guard.

Note:

Toothed belt must not be pinched between oil pump and toothed belt pulley when tightening vibration damper.

- Tighten lower toothed belt guard (10 Nm).

13-14

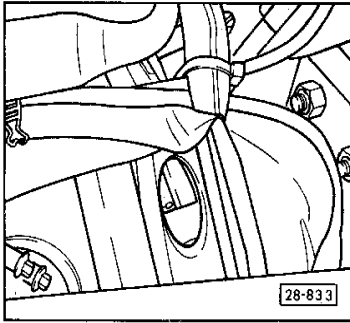

Note:
Instead of "0", notch can be made on flywheel as TDC marking.

- ◀ - Check TDC position of crankshaft

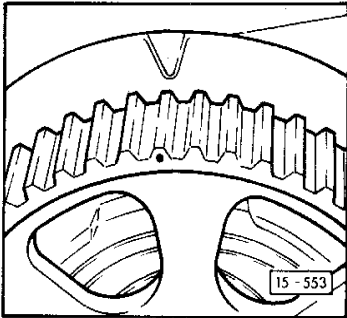

- ◀ - ... and camshaft again. Markings must align.

Note:
Markings with cylinder head or engine removed
- Page 13-13.

13-15

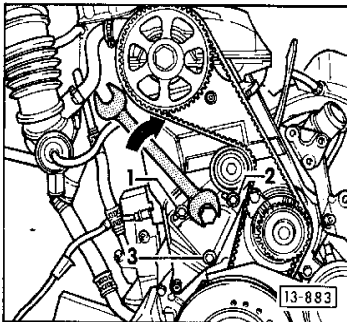

- ◀ - Fit toothed belt via idler pulley and coolant pump on camshaft sprocket.
- Tension toothed belt by turning tensioner toward right -arrow- with bolts -1 ... 3- loosened.

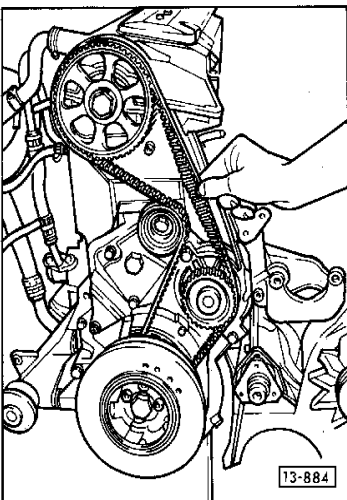

- ◀ - It must be possible to just twist toothed belt by 90° in centre between camshaft sprocket and coolant pump with thumb and forefinger.
- Tighten tensioner bolts to 20 Nm.
- Check basic adjustment of Hall sender - see Workshop Manual Audi 100 "Motronic Ignition and Injection System".

13-16

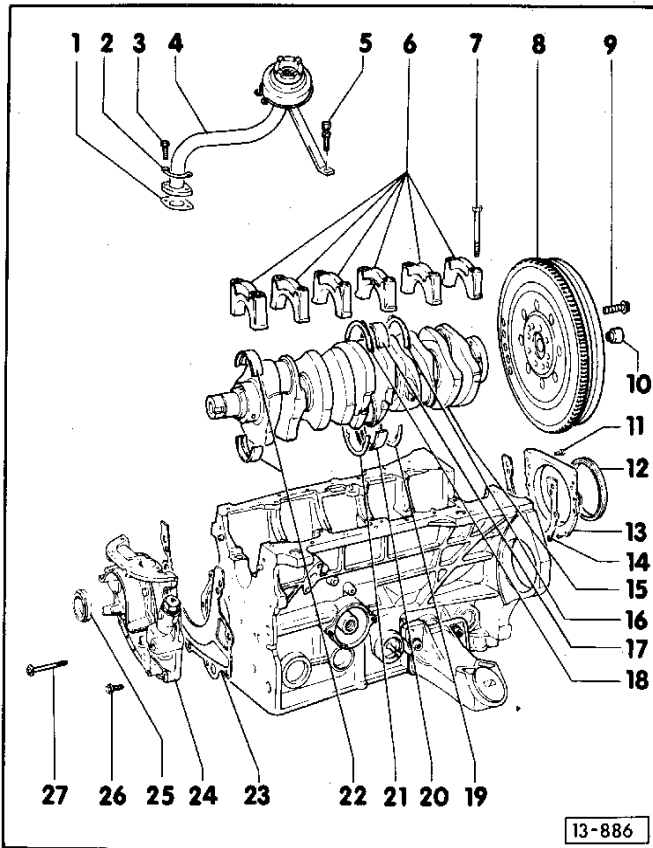

DISMANTLING AND ASSEMBLING CYLINDER BLOCK, CRANKSHAFT AND FLYWHEEL

Note:

- o If metal shavings and abrasion in large quantities - caused by scoring damage, such as piston, crankshaft or conrod bearing damage - are discovered in engine oil during engine repairs, crankcase and oil passages must be carefully cleaned in order to avoid further damage. Oil cooler must be checked for shavings and renewed if necessary - see Repair Group 17.
- o Servicing clutch - see Workshop Manual Audi 100 "5-Gear Manual Gearbox 01A 4-Wheel Drive", Repair Group 30.
- o Always renew seals.

- 1- Intake pipe gasket
o Renew.
- 2- Securing plate
o Renew
- 3- 10 Nm
- 4- Suction pipe
o Attach to oil pump first

13-17

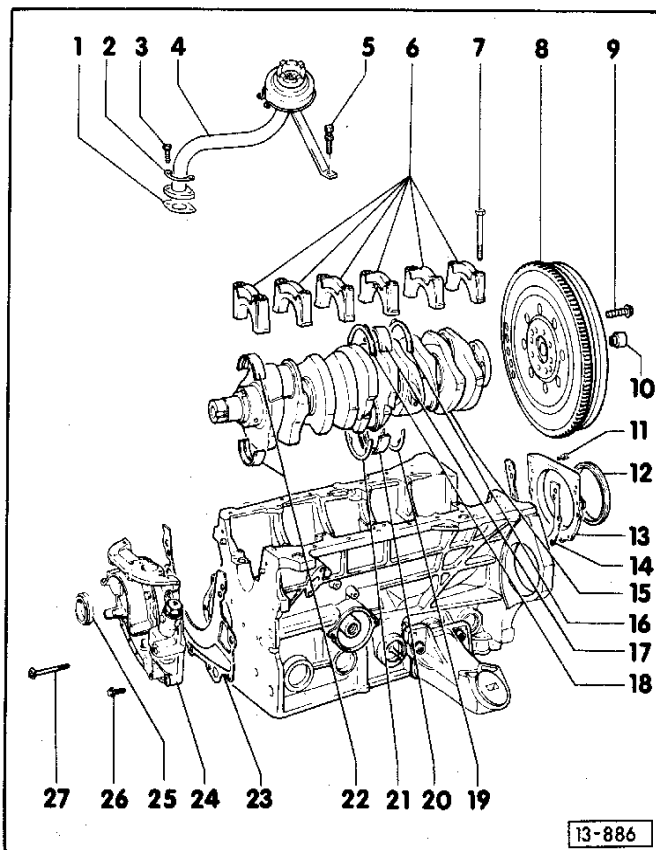

- 5- 10 Nm
- 6- Bearing cap
o Bearing cap 1: Belt pulley end
o Retaining lugs on bearing shells must align
o Watch bore offset
- 7- 65 Nm
- 8- Two-part flywheel
o Reduces rotational vibration in power train
o Removing and installing - Fig. 7, Page 13-24
o With welded-on lugs for ignition firing point and firing angle
o Measure distance from lug to ignition firing point sender (-G4) and distance from flywheel to engine speed sender (-G28) - Page 13-25
- 9- 30 Nm + 1/4 turn (90°)
o Renew
- 10- Needle bearing
o Lubricate with MOS₂ grease
o Driving out - Fig. 5, Page 13-23
o Driving in - Fig. 6, Page 13-23
- 10- 10 Nm

13-18

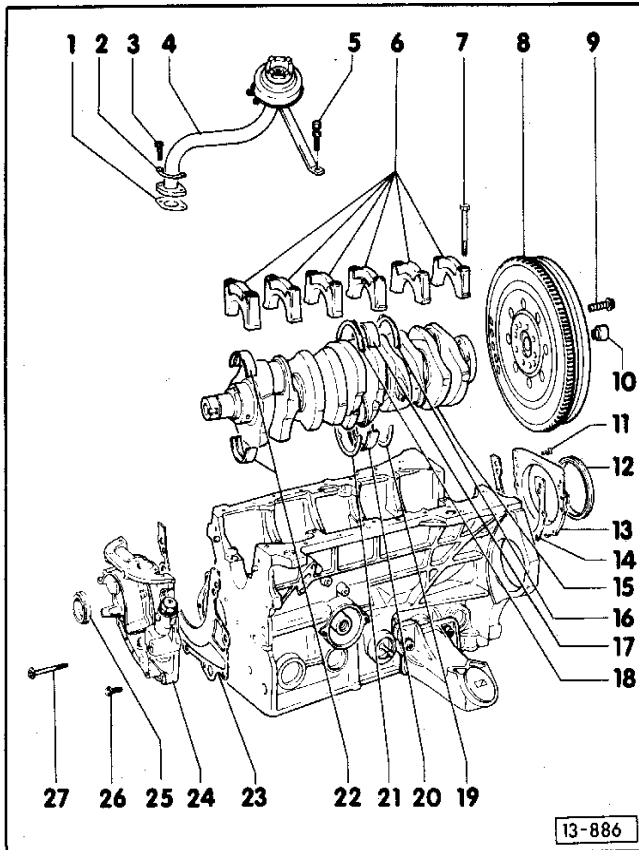

- 12- Oil seal
 - o Pressing out - Fig. 1, Page 13-21
 - o Pressing in - Fig. 2, Page 13-21
- 13- Sealing flange
- 14- Gasket
 - o Renew
- 15- Crankshaft
 - o Measuring axial clearance - Fig. 8, Page 13-24
 - o Check radial clearance with Plastigage - Page 13-28
 - o Crankshaft dimensions - Page 13-27
- 16- Thrust washer
 - o For cap
 - o Watch how secured
- 17- Bearing shell 4
 - o With thrust washers
 - o For cap without oil groove
- 18- Thrust washer
 - o For cap
 - o Watch how secured
- 19- Thrust washer
 - o For cylinder block
 - o Without retaining lug

13-19

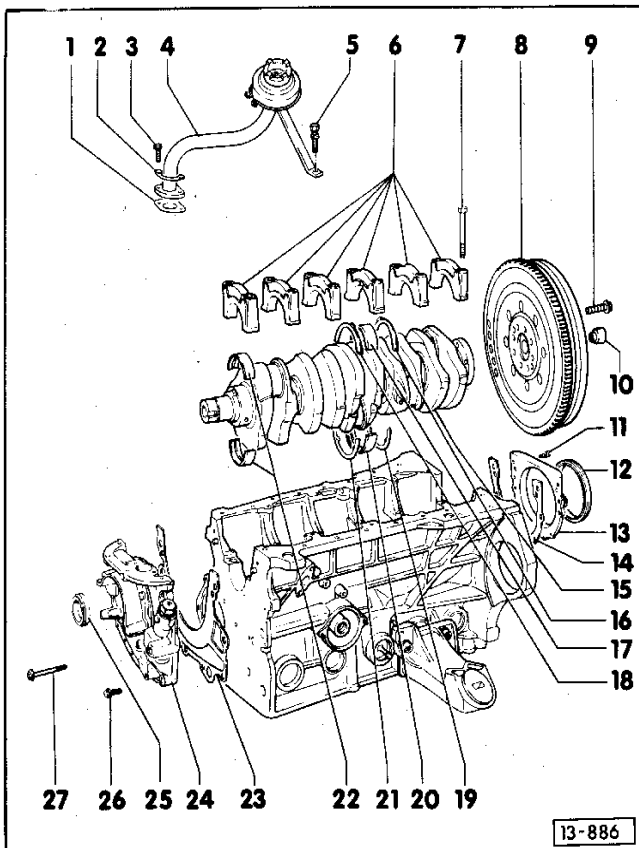

- 20- Bearing shell 4
 - o With thrust washer
 - o For cylinder block with oil groove
- 21- Thrust washer
 - o For cylinder block
 - o Without retaining lug
- 22- Bearing shells 1, 2, 3, 5 and 6
 - o For cap without oil groove
 - o For cylinder block with oil groove
 - o Do not interchange worn bearing shells
 - o Retaining lug must engage in recess of crankcase/bearing cap
- 23- Oil pump gasket
- 24- Oil pump
 - o Watch crankshaft drive when installing pump
- 25- Oil seal
 - o Pulling out - Fig. 3, Page 13-22
 - o Pressing in - Fig. 4, Page 13-22
- 26- 10 Nm
- 27- 20 Nm

13-20

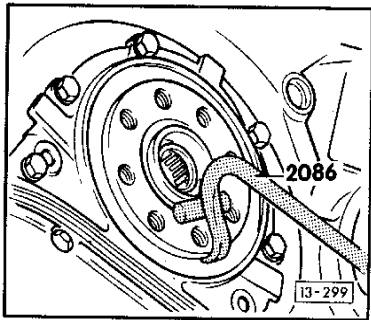

◀ Fig. 1 Pressing out oil seal for crankshaft (flywheel end)

- Removing and installing flywheel - Page 13-31.
- Press out oil seal with puller hook 2086.

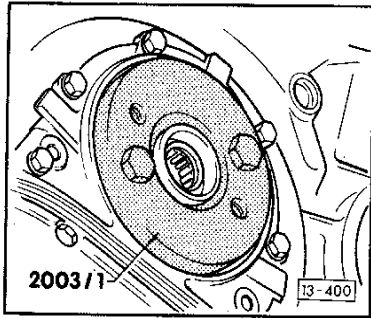

◀ Fig. 2 Pressing in oil seal for crankshaft (flywheel end)

- Lightly oil sealing lip and outer edge of oil seal before installing.
- Press in oil seal with installing tool 2003/1 as far as possible.

13-21

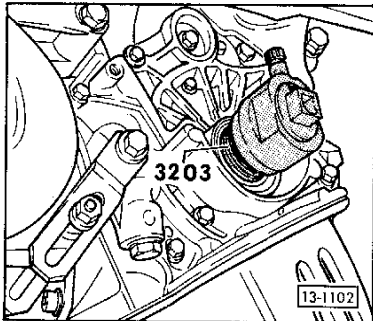

◀ Fig. 3 Pulling out crankshaft oil seal (pulley end)

- Removing toothed belt - Page 13-10
- Removing vibration damper - Page 13-9.
- Pull out oil seal with oil seal puller 3203.

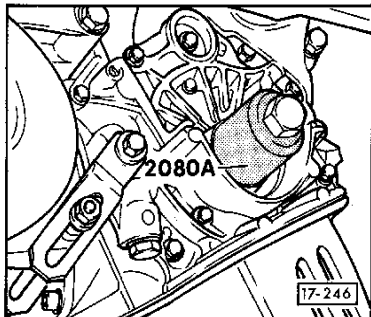

◀ Fig. 4 Pressing in crankshaft oil seal (pulley end)

- Lightly oil sealing lip and outer edge of oil seal before installing.
- Fit oil seal over installing sleeve from 2080 A.
- Press in oil seal flush with oil pump housing using installing sleeve 2080 A (use securing bolt of vibration damper).

Note:

If crankshaft shows signs of scoring, press oil seal home.

13-22

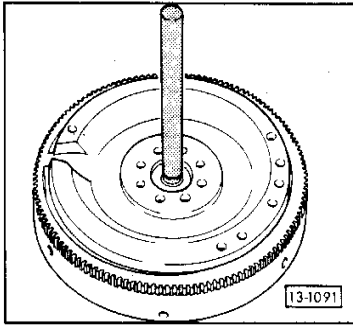

◀ Fig. 5 Driving out needle bearing

- o Flywheel removed
- Drive out bearing with 20 mm dia. drift from backside of flywheel.

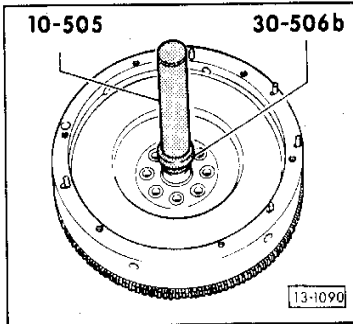

◀ Fig. 6 Driving in needle bearing

- o Closed side of bearing points towards crankshaft.
- Oil outside of bearing housing.
- Drive in flush with flywheel (clutch side) with drift 10-505 and pressing tool 30-506 b.

13-23

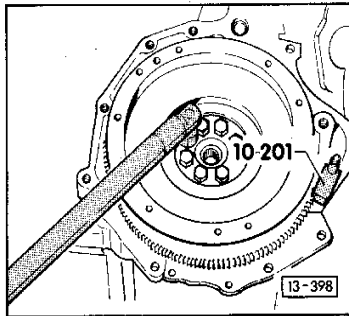

◀ Fig. 7 Removing and installing flywheel

- Switch around brace 10-201 when installing.
- o Tightening torque: 30 Nm + 1/4 turn (90°).

Note:

Flywheel can only be fitted in one position - holes for securing bolts are offset.

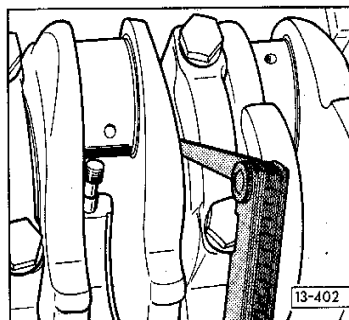

◀ Fig. 8 Measuring crankshaft axial clearance

- Measure axial clearance at No. 4 bearing (thrust bearing).

New: 0.07 ... 0.23 mm.
Wear limit: 0.30 mm.

13-24

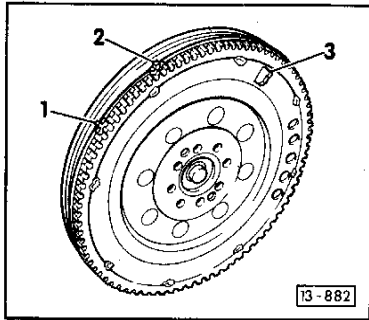

MEASURING DISTANCE FROM LUG TO IGNITION FIRING POINT SENDER (-G4) AND DISTANCE FROM FLYWHEEL TO ENGINE SPEED SENDER (-G28)

- ◀ 1, 2- Firing angle lugs (for ignition tester)
- 3- Ignition firing point lugs (for ignition firing point sender -G4).

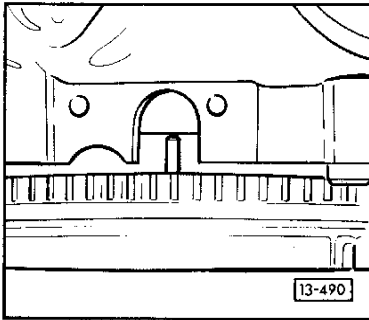

- ◀ - Turn flywheel until lug is positioned under opening of ignition firing point sender.

13-25

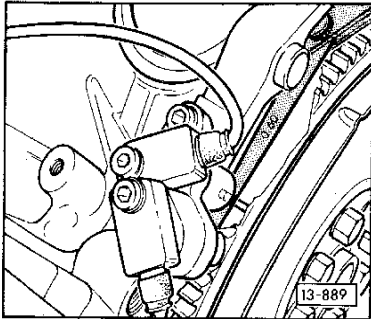

- Screw in ignition firing point sender.
 - ◀ - Insert feeler gauge between lug and ignition firing point sender.
- Specified value: 0.45 ... 1.25 mm.

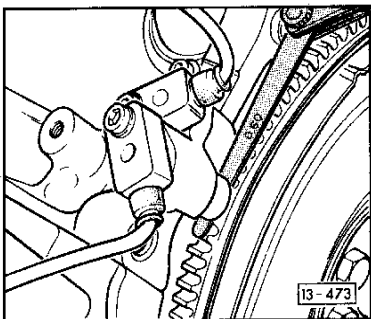

- ◀ - Insert feeler gauge between flywheel tothing and engine speed sender.
- Specified value: 0.50 ... 1.25 mm.

13-26

CRANKSHAFT DIMENSIONS

(Dimensions in mm)

Honing dimension	Main bearing journal dia.	Crank journal dia.
Basic dimension	58.00 -0.022 -0.042	47.80 -0.022 -0.042
1st undersize	57.75 -0.022 -0.042	47.55 -0.022 -0.042
2nd undersize	57.50 -0.022 -0.042	47.30 -0.022 -0.042
3rd undersize	57.25 -0.022 -0.042	47.05 -0.022 -0.042

13-27

CHECKING CRANKSHAFT RADIAL CLEARANCE

o Check radial clearance with Plastigage.

Note:

It is also possible to check radial clearance with engine installed.

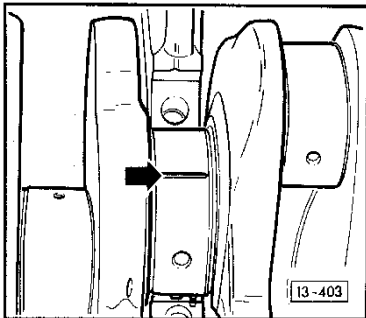

Measuring range of Plastigage strip	Colour	Type
0.025 ... 0.076 mm	green	PG-1
0.050 ... 0.150 mm	red	PR-1
0.100 ... 0.230 mm	blue	PB-1

- Remove crankshaft bearing cap.
- Clean bearing shell and crankshaft journal.
- ◀ - Place Plastigage strip corresponding to bearing width on journal or in bearing shell in axial direction.
- Install cap and shell and tighten to 65 Nm.

Note:

Do not rotate crankshaft.

- Remove bearing cap again.
- ◀ - Compare width of Plastigage strip with measuring scale.

New: 0.018 ... 0.058 mm.
Wear limit: 0.16 mm.

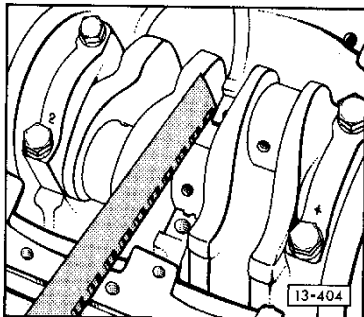

13-28

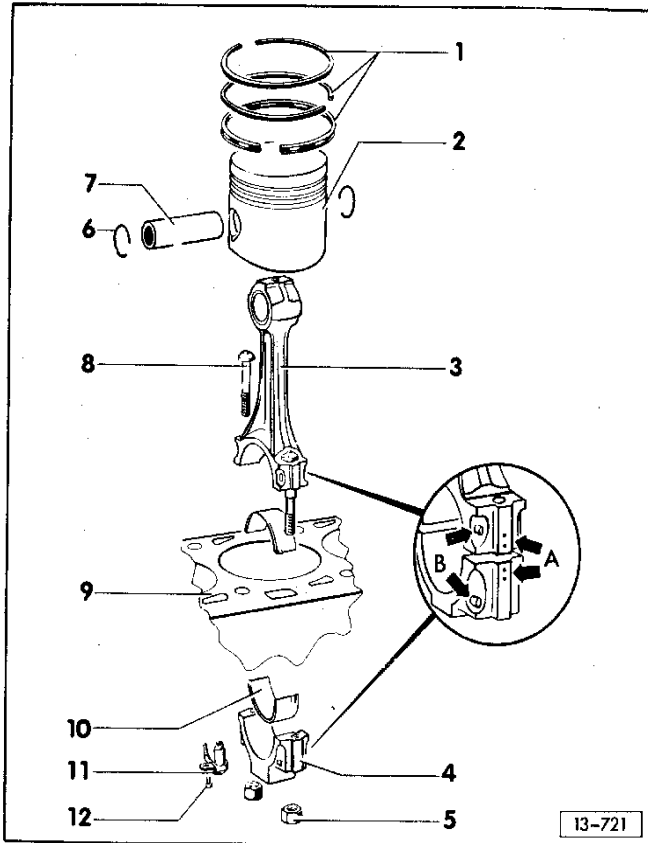

DISMANTLING AND ASSEMBLING PISTONS AND CONRODS

- 1- Piston rings
 - o Offset gaps by 120°
 - o "TOP" marking points toward piston crown - Fig. 5, Page 13-34
 - o Removing and installing - Fig. 6, Page 13-34
 - o Checking side clearance - Fig. 7, Page 13-35
 - o Checking ring gap - Fig. 8, Page 13-35
- 2- Piston
 - o Mark installation position and cylinder number - Fig. 1, Page 13-32
 - o Checking - Fig. 4, Page 13-33
 - o Removing and installing - Fig. 2, Page 13-32
 - o Arrow on piston crown points toward pulley end
 - o Piston dimensions - Page 13-37
- 3- Conrod
 - o Always renew as set
 - o Mark cylinder number with punch -A-
 - o Installation position: Markings -B- point toward pulley end

13-29

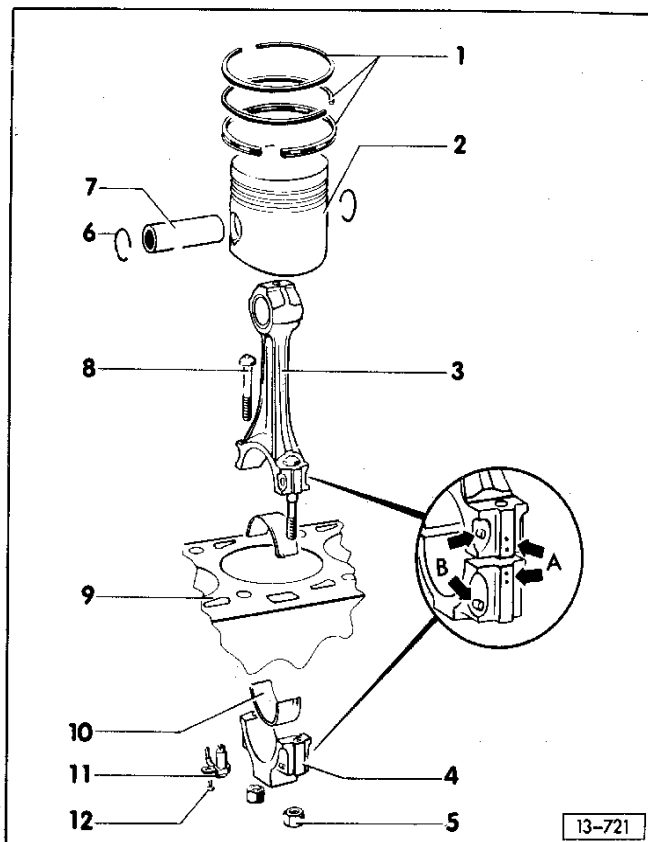

- 4- Conrod bearing cap
 - o Mark cylinder number with punch -A-
 - o Installation position: Markings -B- point toward pulley end
- 5- 30 Nm + 1/4 turn (90°)
 - o Only renew when engine is completely dismantled
 - o Oil contact surfaces
 - o To measure radial clearance, tighten to 30 Nm, but no further
- 6- Circlip
 - o Lever out - Fig. 3, Page 13-33
- 7- Piston pin
 - o Remove and install with drift 10-508
 - o If difficult to remove, heat piston to approx. 60 °C
- 8- Conrod bolt
 - o Only renew when engine is completely dismantled
- 9- Cylinder block
 - o Checking cylinder bores - Fig. 9, Page 13-36
 - o Piston and cylinder dimensions - Page 13-37

13-30

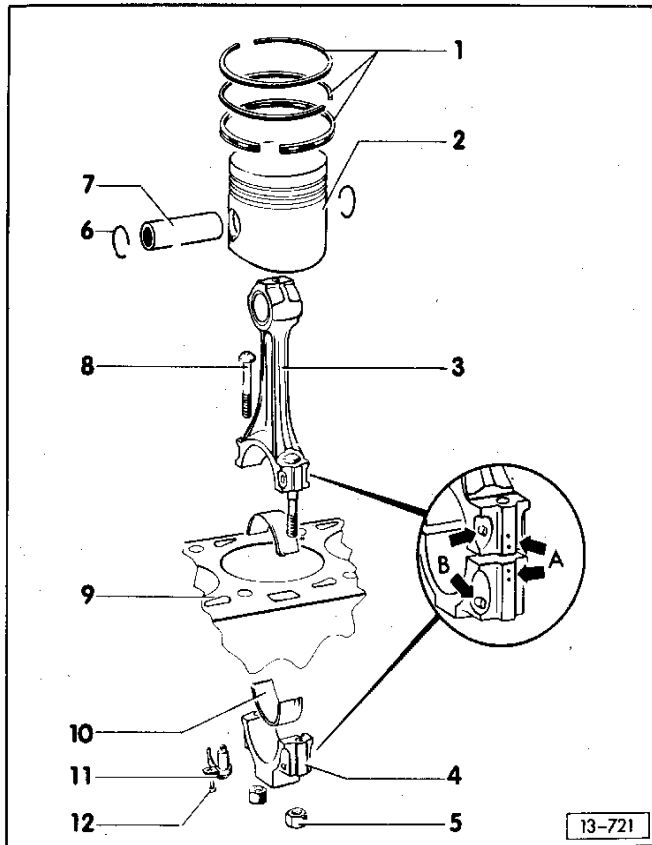

- 10- Bearing shell
 - o Note installation position
 - o Do not interchange used bearing shells
 - o Observe marking (original dimensions/oversize)
 - o Retaining lugs must engage in recesses in bearing caps and conrod
 - o Measuring axial clearance - Fig. 10, Page 13-36
 - o Checking radial clearance with Plastigage - Page 13-38
- 11- Oil spray jet
 - o For cooling piston
- 12- 10 Nm
 - o Install with locking compound D6

13-31

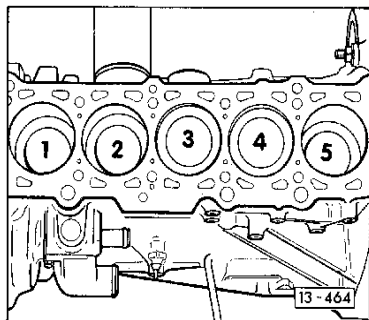

◀ Fig. 1 Marking piston installation position

- o Arrow on piston crown points toward pulley end. Mark cylinder number -1 to 5-
- o Clearly mark sequence on piston crown with waterproof felt pen.

Important!
Do not use punch, as piston crown is coated.

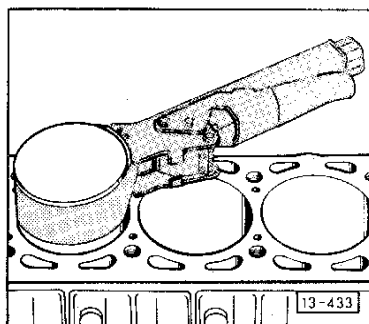

◀ Fig. 2 Removing and installing piston

- o Install with piston ring compressor.

13-32

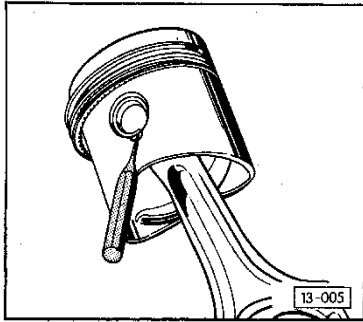

◀ Fig. 3 Levering out circlip

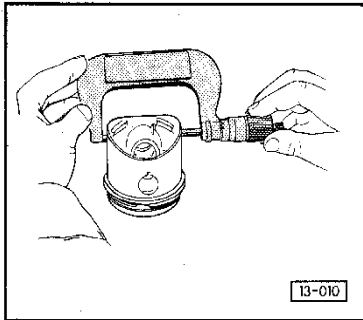

◀ Fig. 4 Checking piston

- o Measure approx. 10 mm from bottom of skirt and 90° offset to piston pin axis.
- o Maximum deviation from specified dimension:
max. 0.04 mm.

13-33

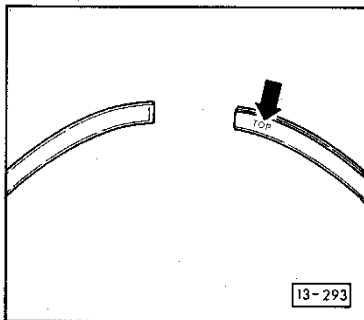

◀ Fig. 5 Installation position of piston rings

- o "TOP" must face toward piston crown.
- o Chamfer on plane ring must face toward piston crown.
- o Step on stepped ring must face toward piston pin.

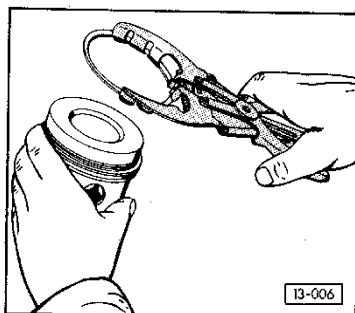

◀ Fig. 6 Removing and installing piston rings

- o Remove and install with piston ring pliers.

13-34

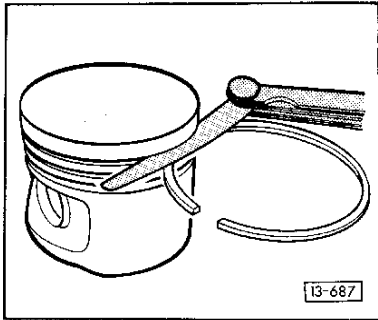

◀ Fig. 7 Checking piston ring side clearance in groove

- Clean ring groove before checking.

New: 0.04 ... 0.072 mm.
Wear limit: 0.1 mm.

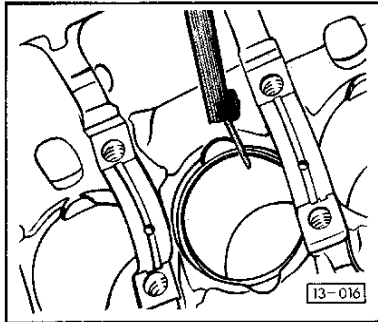

◀ Fig. 8 Checking piston ring gap

- Push ring squarely into lower end of cylinder until it is approx. 15 mm from cylinder edge.

New: 0.15 ... 0.35 mm.
Wear limit: 1.0 mm.

13-35

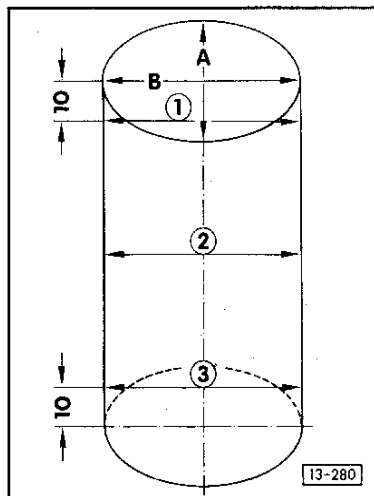

◀ Fig. 9 Checking cylinder bores

- Measure bores at 3 locations diagonally across engine -A- and longitudinally -B-.

- o Use internal dial gauge, 50 ... 100 mm.
- o Deviation from nominal dimension: max. 0.08 mm.

(Piston and cylinder dimensions - Page 13-37)

Note:

Cylinder bores must not be measured when cylinder block is mounted on repair stand with adapter VW 540 -Repair Group 10-, as incorrect measurements are then possible.

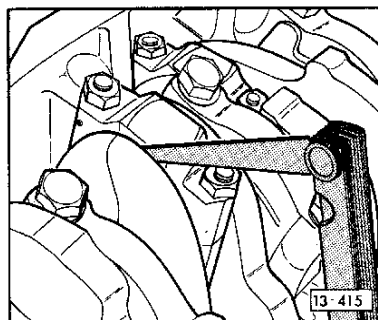

◀ Fig. 10 Measuring conrod axial clearance

- o Wear limit: 0.4 mm.

13-36

PISTON AND CYLINDER DIMENSIONS

(Dimensions in mm)

Honing dimension	Piston dia.	Cyl. bore dia.
Basic dimension	80.98	81.01
1st oversize	81.23	81.26
2nd oversize	81.48	81.51

13-37

CHECKING CONROD RADIAL CLEARANCE

o Check radial clearance with Plastigage.

Note:

It is also possible to check radial clearance with engine installed.

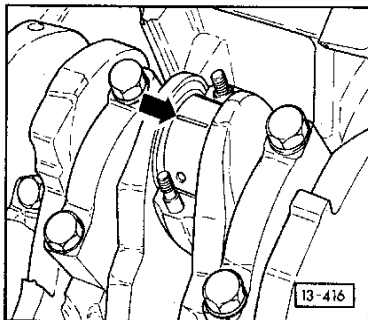

Measuring range of Plastigage strip	Colour	Type
0.025 ... 0.076 mm	green	PG-1
0.050 ... 0.150 mm	red	PR-1
0.100 ... 0.230 mm	blue	PB-1

- Remove conrod bearing cap.
- Clean bearing shell and crank journal.
- ◀ - Lay Plastigage strip corresponding to width of crankshaft journal in axial direction journal or in bearing shell.
- Install conrod bearing cap with bearing shell and tighten to 30 Nm, but no further.

Note:

Do not rotate crankshaft.

- Remove conrod bearing cap again.
- ◀ - Compare width of Plastigage strip with measuring scale.

Conrod radial clearance:

New: 0.010 ... 0.05 mm.
Wear limit: 0.12 mm.

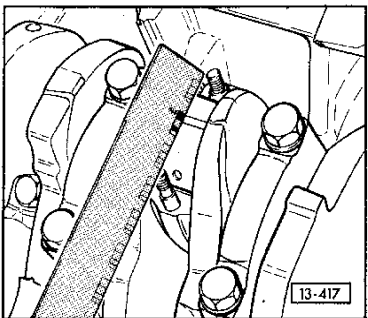

13-38

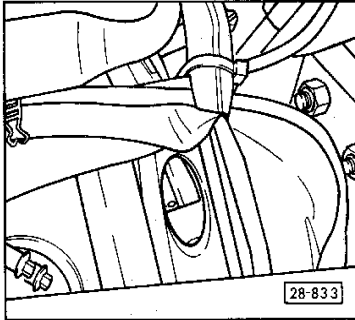

CHECKING BASIC MECHANICAL ADJUSTMENT OF ENGINE

- o Toothed belt tension OK - Page 13-16.
- Remove upper toothed belt guard.

Note:

- o Hexagon flange (SW 32) is provided on hydraulic pump for turning engine by hand.
- o Instead of "0", notch may also be made on flywheel as TDC marking.

- ◀ - Turn crankshaft to TDC, cylinder 1. TDC marking must be positioned below edge in inspection hole ...

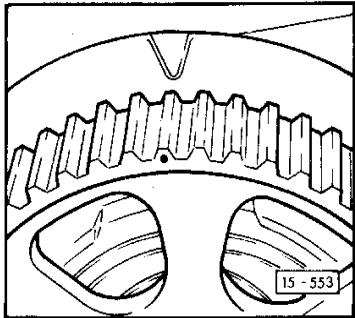

- ◀ - ... and marking on camshaft sprocket and cylinder head cover align.

Note:

- o If markings on camshaft are offset by 1/2 turn, turn crankshaft one additional turn.
- o If markings do not align, toothed belt has jumped. Adjusting - see "Removing and installing toothed belt" - Page 13-10 and check basic setting of Hall sender - Workshop Manual Audi 100 "Motronic Ignition and Injection System".

REMOVING AND INSTALLING CYLINDER HEAD

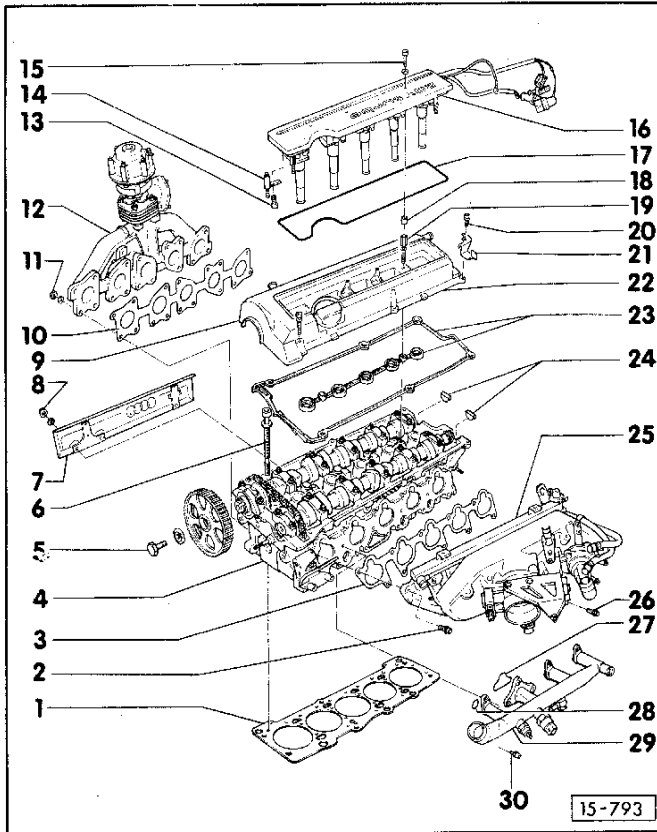

Note:

- o Cylinder head can be removed and installed with engine installed.
- o Removing and installing toothed belt - see Repair Group 13.
- o Removing and installing injectors - see Workshop Manual Audi 100 "Motronic Injection and Ignition System".
- o Cylinder heads with cracks between valve seats or between valve seat insert and spark plug threads may be reused without reducing service life, provided cracks do not exceed max. 0.5 mm in width, or when no more than first spark plug threads are cracked.
- o When installing replacement cylinder head with fitted camshaft, contact surfaces between bucket tappets and cam surfaces must be oiled after installing cylinder head.
- o When renewing cylinder head or cylinder head gasket, renew all coolant.
- o Checking compression - Page 15-7.

15-1

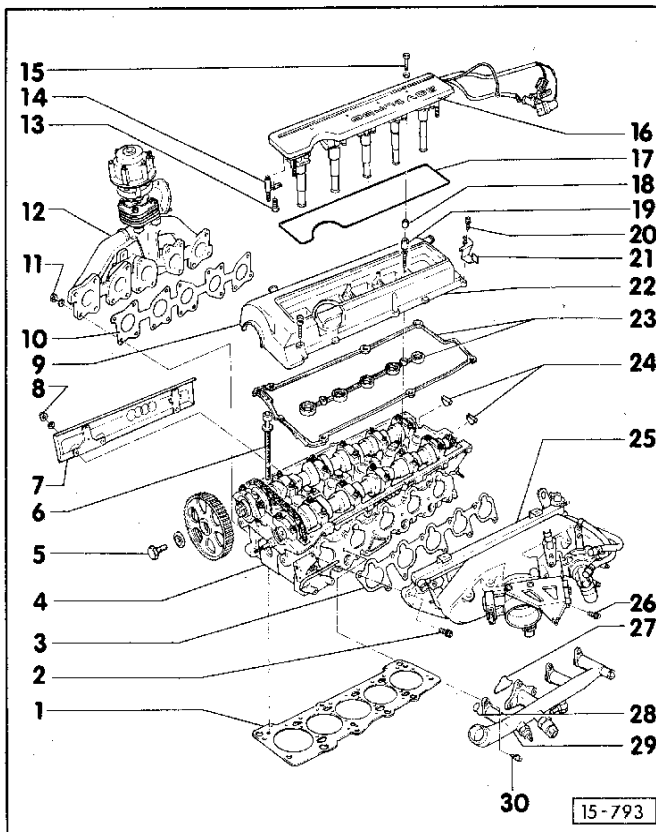

- 1- Cylinder head gasket
 - o Renew
 - o Ensure correct installation position: "OBEN" marking or part number must face cylinder head
 - o Fit gasket over centring pins in cylinder block
- 2- 20 Nm
- 3- Gasket
 - o Renew
- 4- Cylinder head
 - o Checking for distortion - Fig. 1, Page 15-5
 - o Refinishing - Fig. 2, Page 15-5
 - o Installing - Page 15-6
 - o Servicing valve train - Page 15-9
- 5- 65 Nm
- 6- Cylinder head bolts
 - o Renew
 - o Follow installation instructions and sequence when loosening and tightening - Page 15-6
- 7- Heat shield
- 8- 65 Nm

15-2

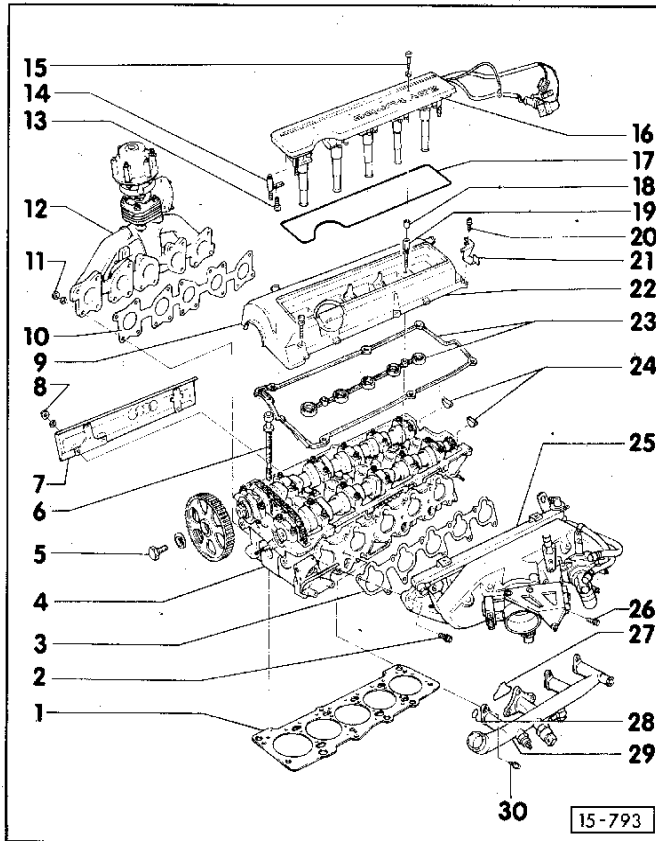

- 9- 10 Nm
o Tighten diagonally
- 10- Gasket
o Flanged surface must face exhaust manifold
- 11- 25 Nm
o Renew
- 12- Exhaust manifold
o With turbocharger
- 13- 10 Nm
- 14- Spring with bracket
- 15- 10 Nm
- 16- Cover
o With ignition coils
- 17- Gasket
o Only renew if damaged
o Insert in groove in cover
- 18- (eliminated)
- 19- 10 Nm
- 20- 10 Nm

15-3

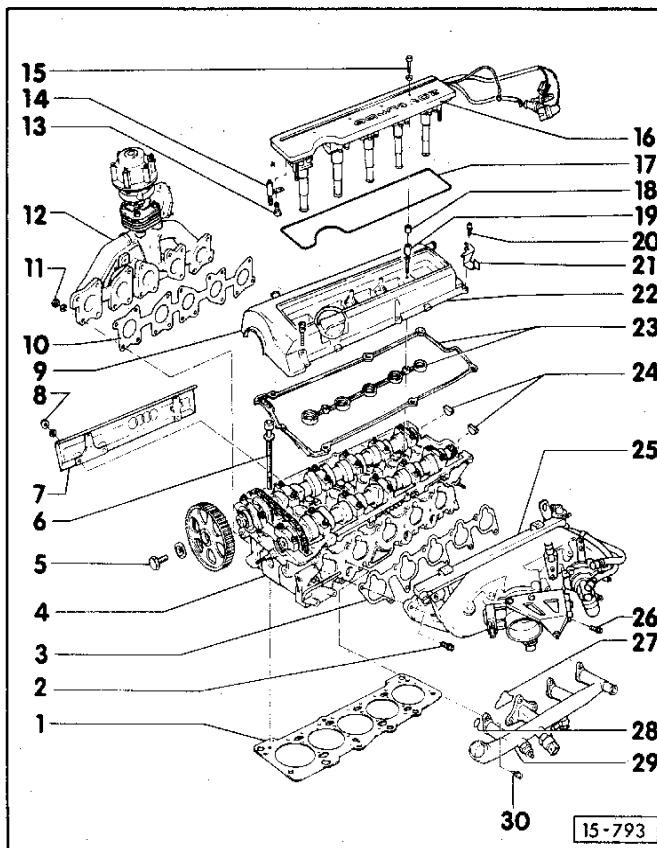

- 21- Bracket
o For vacuum hoses
- 22- Cylinder head cover
- 23- Gasket for cylinder head cover
o Only renew if damaged
o Insert in groove on cylinder head cover
- 24- Plugs
o Only renew if damaged
- 25- Intake manifold
o Use Allen socket V.A.G 1669 to remove and install
- 26- Bolt
o For oil dipstick guide tube
o 10 Nm
- 27- Gasket
o Renew
- 28- O-ring
o Renew
- 29- Coolant pipe
- 30- 10 Nm

15-4

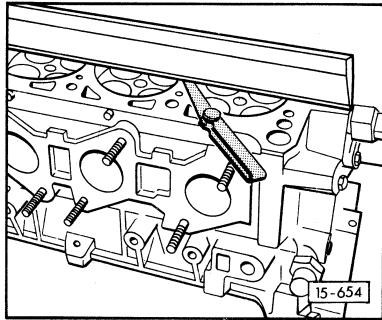

◀ Fig. 1 Checking cylinder head for distortion

- Measure with feeler gauge at several locations.
- Distortion: max. 0.1 mm.

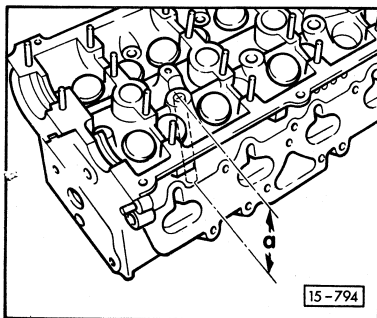

◀ Fig. 2 Refinishing cylinder head

- o Refinishing cylinder head (grinding flat) is permissible up to minimum dimension $a = 118.1$ mm (measured through bolt hole).

15-5

INSTALLING CYLINDER HEAD

Note:

- o Renew cylinder head bolts.
- o There must be no oil or coolant in blind holes of cylinder head bolts in cylinder block.
- Before fitting cylinder head, set crankshaft and camshaft in cylinder head to TDC cylinder 1.
- Fit cylinder head gasket over centring pins: "OBEN" or part number must face cylinder head (watch hole pattern).
- Install cylinder head fit cylinder head bolts and tighten by hand.
- ◀ - Tighten cylinder head bolts in total of three stages - for sequence, see diagram.
- Tightening torques (engine cold):
 - o Stage I = 40 Nm
 - o Stage II = 60 Nm
 - o Stage III = 1/2 turn (180°) further with rigid spanner without stopping (2 x 90° is also permissible).

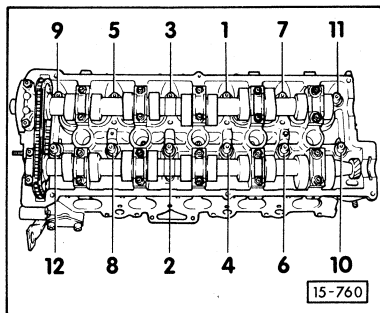

Note:

- o Loosen cylinder head bolts in reverse order.
- o Additional retightening of bolts is not required.

15-6

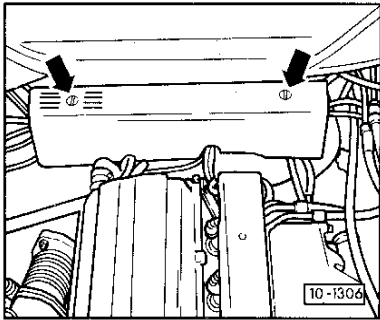

CHECKING COMPRESSION PRESSURE

o Engine warm (Coolant temperature gauge at approx. 80 °C).

- ◀ - Turn quick fasteners -arrows- on connector cover on rear engine compartment bulkhead 90° to left and remove cover.

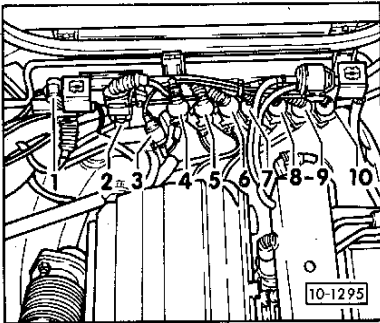

- ◀ - Mark and separate connectors -5- and -6- (to ignition coils).
- Remove cover with coils on cylinder head cover - Page 15-3.
- Unscrew all spark plugs with spark plug spanner 3122 A.

15-7

- Check compression pressure with compression pressure recorder V.A.G 1381 and adapter 1381/1.

o Throttle valve fully open.

- Operate starter until no further pressure increase is indicated by tester.

Compression pressures (in bar)

- o Specified value = 9.0 ... 13.0
- o Wear limit = 7.0
- o Max. permissible pressure difference between individual cylinders = 3.0

15-8

SERVICING VALVE GEAR

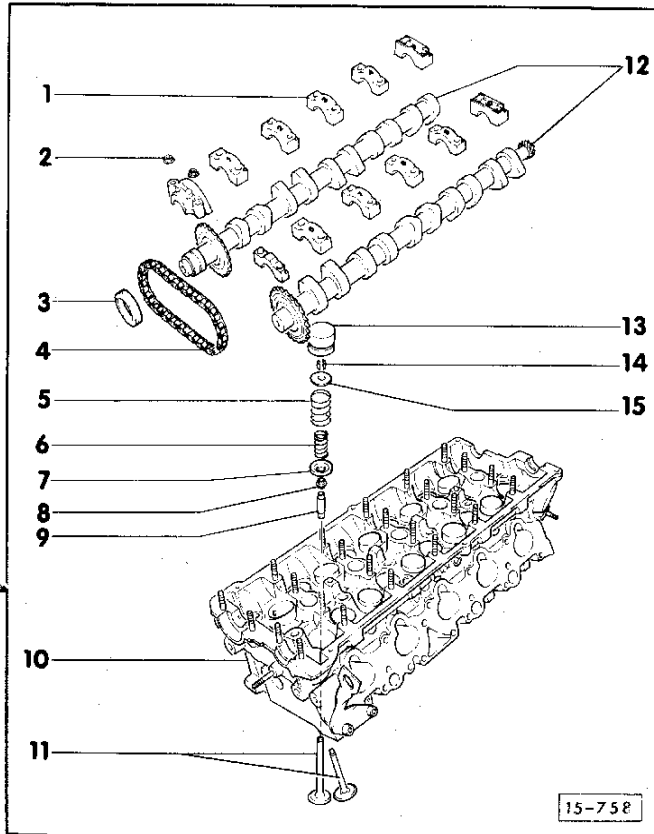

Note:

Cylinder heads with cracks between valve seats or between valve seat inserts and spark plug threads may still be used without reducing service life, provided cracks do not exceed max. 0.5 mm in width, or when no more than first spark plug threads are cracked.

- 1- Bearing cap
 - o Observe installation position and numbering - Fig. 1 and 2, Page 15-12
 - o Installation sequence - see "Removing and installing camshafts" - Page 15-21
- 2- 15 Nm
- 3- Oil seal
 - o Renew - Page 15-18
- 4- Drive chain
- 5- Outer valve spring
 - o Removing and installing - see item 14
- 6- Inner valve spring
 - o Removing and installing - see item 14

15-9

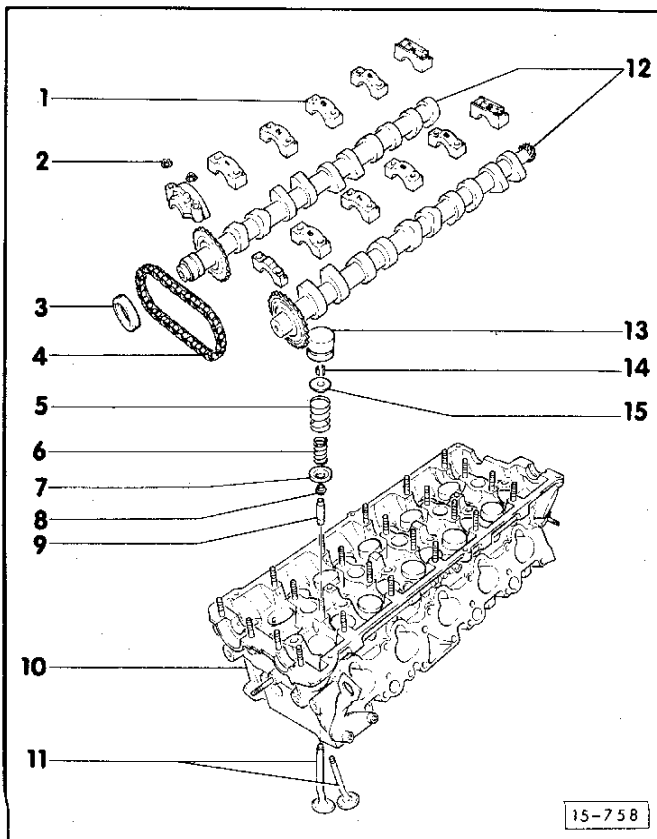

- 7- Lower valve-spring seat
 - o Removing and installing - see item 14
 - o Possible to take off after removing valve stem seal - Page 15-29 or 15-31
- 8- Valve stem seal
 - o Renewing with cylinder head installed - Page 15-29
 - o Renewing with cylinder head removed - Page 15-31
- 9- Valve guide
 - o Checking - Fig. 5, Page 15-15
 - o Renewing - Page 15-27
- 10- Cylinder head
 - o Installing - Page 15-6
 - o Reworking valve seats - Page 15-24
 - o Checking for distortion, reworking - Page 15-5
- 11- Valves
 - o Only grind in, do not rework
 - o Valve dimensions - Fig. 4, Page 15-14
 - o Exhaust valves sodium-filled, follow instructions on scrapping - Page 15-14

15-10

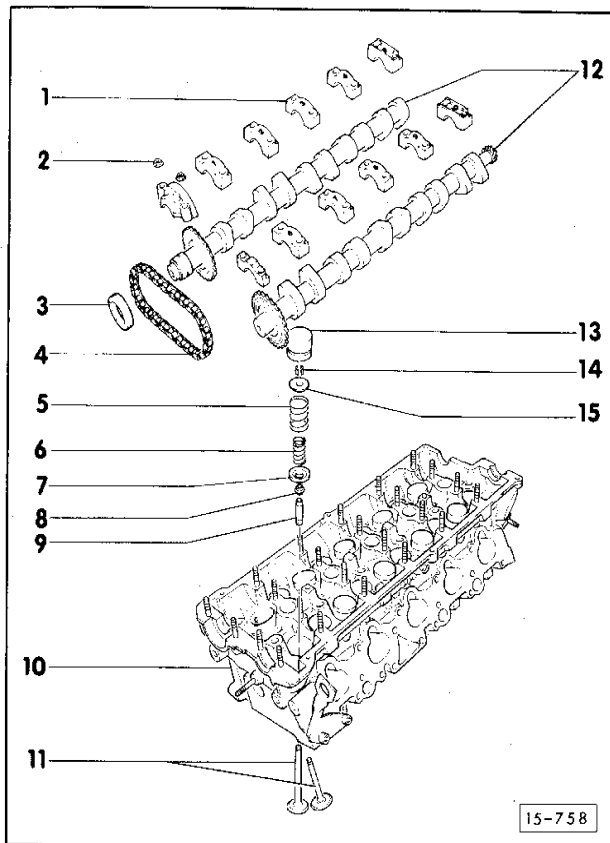

- 12- Camshafts
 - o After installing camshafts, do not start engine for approx. 30 minutes (valves strike pistons), then turn crankshaft 2 rotations
 - o Checking axial clearance (bucket tappets removed) - Fig. 3, Page 15-13
 - o Removing and installing - Page 15-20
 - o Check radial clearance with Plastigage (bucket tappets removed)
- 13- Bucket tappet (hydraulic)
 - o After installing bucket tappets, do not start engine for approx. 30 minutes (valves strike pistons), then turn crankshaft 2 rotations
 - o Oil running surfaces
 - o Do not interchange (mark)
 - o When removing, set aside tappet with running surface facing downward
 - o Checking - Page 15-16
- 14- Valve cutters
 - o Removing and installing :
 - With cylinder head installed, with valve fitting tool 2036 and valve lever VW 541/1 - see "Renewing valve stem seals" - Page 15-29
 - With cylinder head removed - Page 15-31
- 15- Upper valve-spring seat
 - o Removing and installing - see item 14

15-11

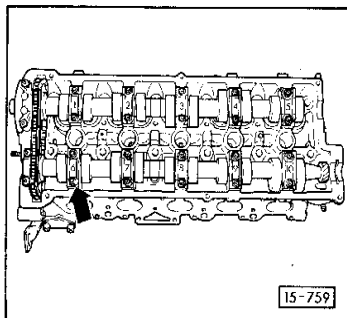

◀ Fig. 1 Installation position of camshaft bearing cap

- o Recesses at corners of bearing caps must point toward intake side of cylinder head -arrow-
- o Install bearing caps according to numbering 1 to 10 on caps as shown in diagram.

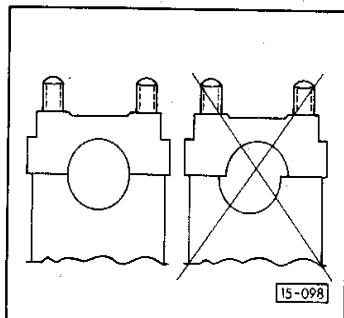

◀ Fig. 2 Installation position of camshaft bearing caps

- o Watch offset. Before installing camshaft, fit bearing caps and determine installation position.

15-12

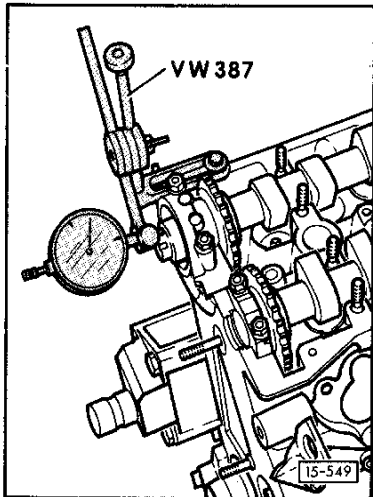

◀ Fig. 3 Checking camshaft axial play

- Remove bucket tappets.
- Camshaft with first and last bearing cap fitted.
- o Chain removed.
- Screw universal measuring gauge bracket VW 387 onto face of cylinder head and insert gauge.
- o Axial clearance:
Wear limit: 0.2 mm.

15-13

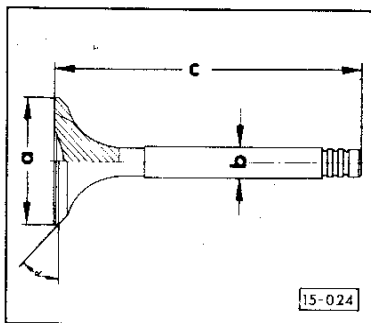

◀ Fig. 4 Valve dimensions

Inlet valve

a = 32.00 mm dia.
b = 6.97 mm dia.
c = 95.50 mm dia.
 $\alpha = 45^\circ$

Exhaust valve

a = 28.00 mm dia.
b = 6.94 mm dia.
c = 98.20 mm dia.
 $\alpha = 45^\circ$

Note:

Valves may not be reworked. Only grinding in is permissible.

Important!

Worn-out sodium-filled exhaust valves cannot simply be scrapped. Using hack saw, valves should be cut in two across middle of stem. During this operation, they must not come into contact with water. Throw maximum of ten valves prepared in this way into bucket of water and step back quickly to avoid any danger from ensuing chemical reaction, during which sodium will burn. Parts treated in this way can then be disposed of with other scrap.

15-14

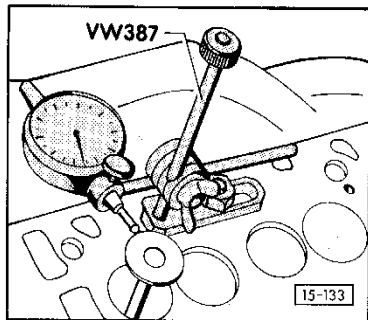

◀ Fig. 5 Checking valve guide

- Screw universal measuring gauge bracket VW 387 onto sealing surface of cylinder head and insert gauge.
- Insert new valve into guide. Valve stem end must seal with guide.

Note:

Due to differing stem diameters, only insert inlet valve into inlet guide and exhaust valve into exhaust guide.

Valve rock:

Wear limit: Inlet valve guide = 1.0 mm.
Exhaust valve guide = 1.3 mm.

15-15

CHECKING HYDRAULIC BUCKET TAPPETS

Important!

After installing new or reinstalling old bucket tappets, and after installing camshafts, engine must not be started for approx. 30 minutes. Otherwise valves strike pistons.

After this period, carefully turn crankshaft two rotations by hand in order to ensure that no valves strike pistons.

Note:

- o Brief valve noise during starting is normal.
- o Do not interchange bucket tappets (mark).
- o Set aside removed tappets on clean surface with running surface (cam side) facing downward.
- o Defective bucket tappets must be renewed (repairs are not possible).

15-16

- Run engine until operating temperature is reached (coolant temperature gauge at approx. 80 °C).
- Increase engine speed to approx. 2500 rpm for 2 minutes.

If tappets are still noisy, locate defective tappet as follows:

- Remove cylinder head cover.
- Rotate crankshaft clockwise until cam of tappet to be checked is pointing upward.
- ◀ - Press down tappet with wooden or plastic wedge. If free travel in excess of 0.1 mm is felt, renew tappet.

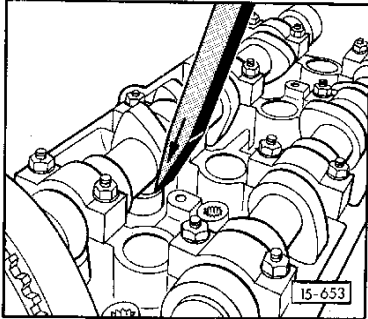

15-17

RENEWING CAMSHAFT OIL SEAL

Removing:

- Remove upper toothed-belt guard.
- ◀ - Rotate crankshaft until No. 1 cylinder is at TDC.
- Slacken toothed belt and remove.
- Remove camshaft sprocket.
- Screw camshaft-sprocket securing bolt with washer into camshaft as far as possible.

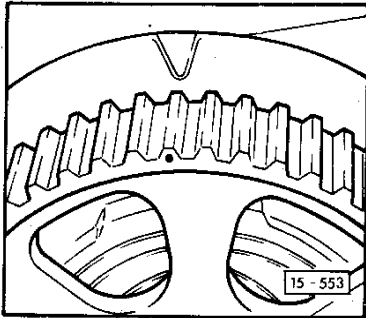

- Unscrew inner section of oil seal extractor 2085 two turns (approx. 3 mm) out of outer section and lock in position with knurled screw.
- ◀ - Oil threaded head of oil seal extractor, place in position and screw into oil seal as far as possible while exerting firm pressure.

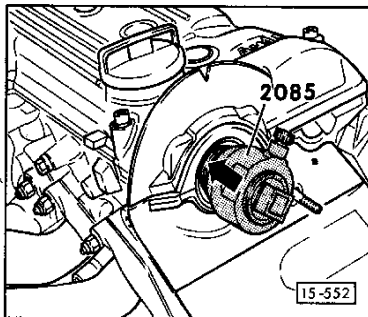

15-18

- Loosen knurled screw and turn inner part of extractor against camshaft until oil seal is extracted.
- Clamp extractor in vice on flats and remove oil seal with pliers.

Installing:

- Lightly oil sealing lip and outer edge of oil seal.
- Push oil seal onto installing sleeve from 10-203.
- Press oil seal home with installing tool 10-203 and offset bolt 10-203/1.

Note:

Do not press oil seal over first shoulder, otherwise oil return hole will be covered.

15-19

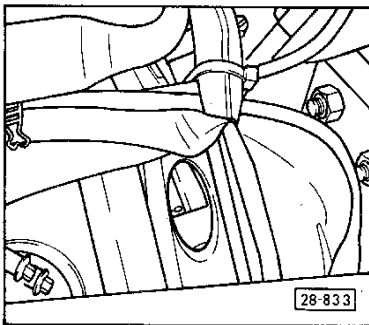

REMOVING AND INSTALLING CAMSHAFTS

Removing:

- Remove upper toothed-belt guard.

Note:

Instead of "0", notch can also be made on flywheel as TDC marking.

- ◀ - Rotate crankshaft until No. 1 cylinder is at TDC. TDC marking must be located under edge in inspection hole ...

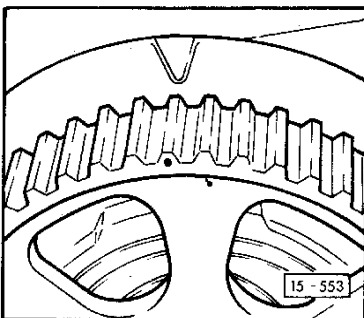

- ◀ - ... and markings on camshaft and cylinder head cover must align.
- If markings on camshaft are 1/2 turn offset, turn crankshaft one additional rotation.

Note:

Hexagon flange (SW 32) is provided on hydraulic pump for turning engine by hand.

15-20

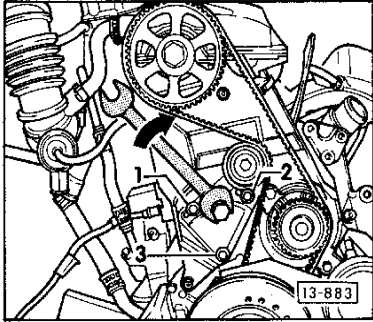

- ◀ - Loosen tensioner bolts -1 ... 3-
- Remove camshaft sprocket.
- Remove cylinder head cover.

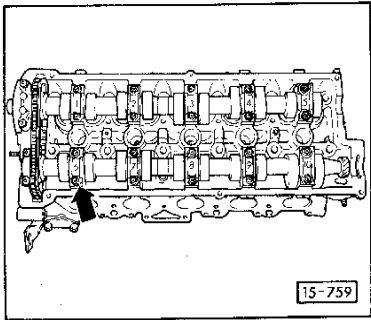

Exhaust camshaft:

- ◀ - Remove bearing cap in front of chain, as well as caps 2 and 4.
- Remove bearing cap 1, 3 and 5 alternately in diagonal sequence.

Inlet camshaft:

- Remove bearing cap in front of chain, as well as 7 and 9.
- Remove bearing caps 6, 8 and 10 alternately in diagonal sequence.

15-21

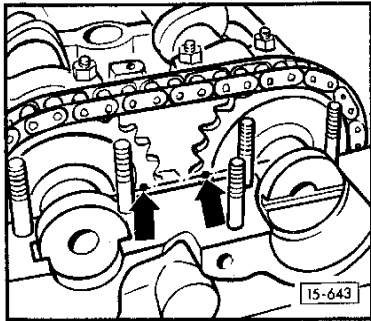

Installing:

- Oil all running surfaces.
- ◀ - Fit camshafts with chain so that markings on chain sprockets align -arrows-.

Note:

- o When installing camshafts, Hall sender housing must be removed.
- o For installing Hall sender housing and basic setting of Hall sender - see Workshop Manual Audi 100 "Motronic Ignition and Injection System".
- o When installing bearing caps, ensure that recesses on corners of caps point toward inlet side of cylinder head - Page 15-12.

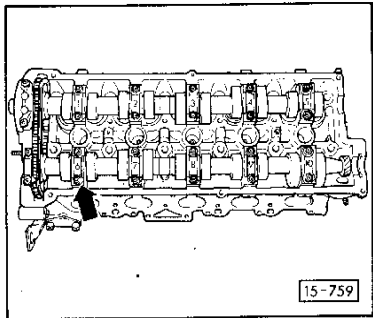

Inlet camshaft:

- ◀ - Tighten bearing caps 6, 8 and 10 alternately in diagonal sequence. Tightening torque: 15 Nm.
- Fit remaining bearing caps. Tightening torque: 15 Nm.

15-22

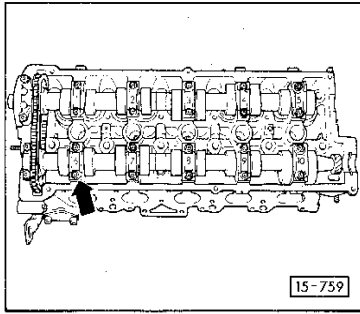

Exhaust camshaft:

- ◀ - Tighten bearing caps 1, 3 and 5 alternately in diagonal sequence.
Tightening torque: 15 Nm.
- Fit remaining bearing caps.
Tightening torque: 15 Nm.
- Renew camshaft oil seals - Page 15-18.
- Fit camshaft sprocket and tighten.
Tightening torque: 65 Nm.
- Install toothed belt - see Repair Group 13.

Important!

After installing new or reinstalling old bucket tappets, and after installing camshafts, engine must not be started for approx. 30 minutes. Otherwise valves strike pistons.

After this period, carefully turn crankshaft two rotations by hand in order to ensure that no valves strike pistons.

15-23

REWORKING VALVE SEATS

Note:

- o When servicing engines with leaky valves, it is not sufficient to rework or renew valve seats and valves. It is also necessary to check valve guides for wear - Page 15-15. This is particularly important when checking engine with high mileage.
- o Only rework valve seats enough to produce perfect contact surface. Before reworking commences, calculate maximum permissible reworking dimension.
- o If this dimension is exceeded, correct functioning of hydraulic tappet can no longer be guaranteed and cylinder head must be renewed.

15-24

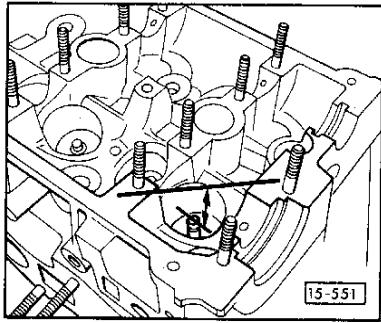

Calculating maximum permissible reworking dimension

- o Maximum permissible reworking dimension is difference between distance -arrow- measured at cylinder head and specified minimum dimension.

Minimum dimension: at inlet valve: 36.0 mm
at exhaust valve: 36.3 mm

Measuring distance -arrow-:

- Insert valve into valve guide and press firmly against valve seat.
- Measure distance -arrow- between valve stem end and upper edge of cylinder head.

Example:

Distance:	37.0 mm
minus minimum dimension:	36.3 mm
= max. perm. reworking dim.	0.7 mm

15-25

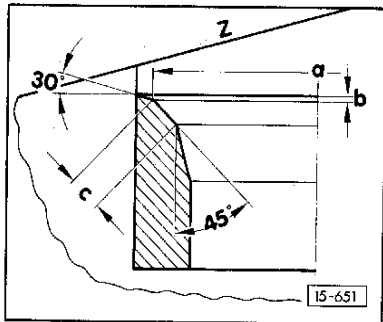

◀ Reworking inlet valve seat

- a = 31.2 mm dia.
- b = (not given)
- c = 1.5 ... 1.8 mm
- If necessary, rework valve seat with 75° reseating tool
- C = Lower edge of cylinder head
- 30°= Upper correction angle
- 45°= Valve seat angle

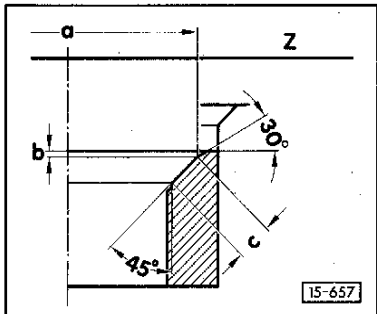

◀ Reworking exhaust valve seat

- a = 27.6 mm dia.
- b = (not given)
- c = approx. 1.8 mm
- C = Lower edge of cylinder head
- 30°= Upper correction angle
- 45°= Valve seat angle

15-26

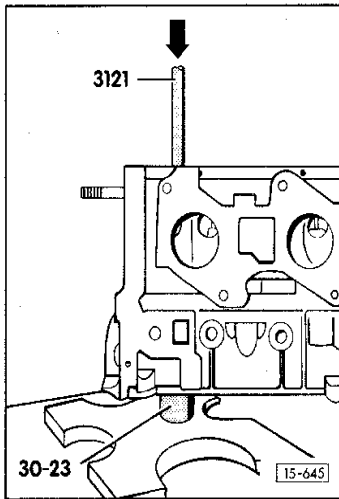

RENEWING VALVE GUIDES

Note:

- o Only renew valve guides on cylinder heads on which permissible reworking dimension of valve seat inserts is at least 0.5 mm. Checking - Page 15-25.
- o If this reworking dimension is exceeded, cylinder head must be renewed.

- ◀ - Press worn valve guides out from combustion chamber side using 3121, using sleeve 30-23 as support.

15-27

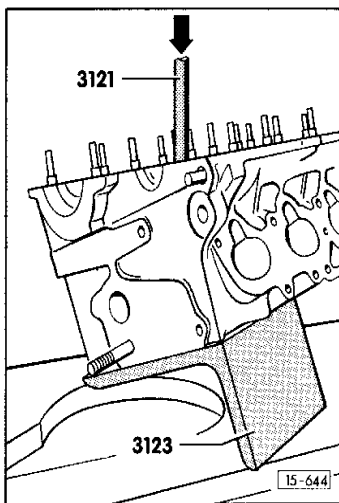

- ◀ - Moisten new guides with oil and press into cold cylinder head from camshaft side with 3121 until shoulder makes contact.

Note:

- o Use support 3123 for pressing in inlet valve guides.
- o After shoulder on guide makes contact, pressure must not exceed 1.0 tonnes, otherwise shoulder may break off.

- Ream out guides with hand reamer 3120, using cutting water.

- Reworking valve seats - Page 15-24.

Note:

When reworking valve seats, observe permissible reworking dimension - Page 15-25.

15-28

RENEWING VALVE-STEM OIL SEALS
(With cylinder head installed)

- Remove camshafts and bucket tappets - Page 15-20.
- Remove spark plugs with spark plug spanner 3122 A.
- Set piston of respective cylinder to BDC.
- Screw compressed air hose VW 653/3 into spark plug thread and apply continuous pressure of at least 6 bar.

Inlet side:

- ◀ - Bolt fitting tool 2036 to cylinder head and adjust to height of studs.
- Remove valve springs with valve lever VW 541/1 and pressing piece VW 541/5.

Exhaust side:

- Remove valve springs in same manner as described for inlet side.

Note:

- ◀ Tight cotters can be loosened by tapping lightly on lever VW 541/1 with hammer.

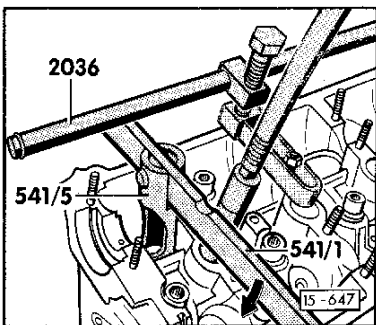
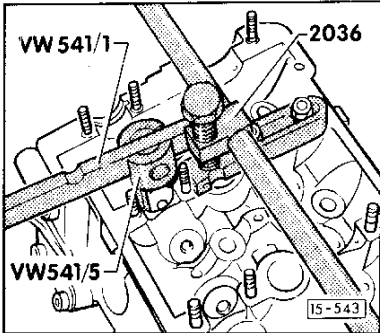

15-29

- Remove valve stem seals with puller 3047 A.
- ◀ - Fit plastic sleeve -A- onto valve stem. Oil valve stem seal -B-, insert into fitting tool 3129 and push down carefully onto valve guide.

Note:

To prevent damaging valve stem seal, always use plastic sleeve (included with valve stem seals).

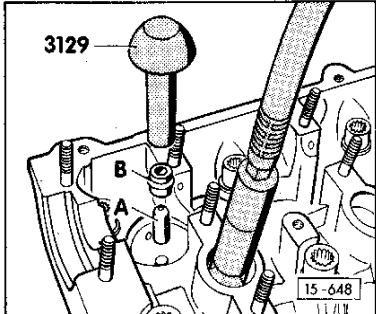

15-30

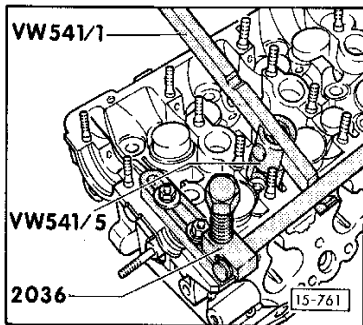

RENEWING VALVE-STEM OIL SEALS
(With cylinder head removed)

- Remove camshafts and bucket tappets - Page 15-20.
- Unscrew spark plugs with spark plug spanner 3122 A.

Inlet side:

- ◀ - Bolt fitting tool 2036 to cylinder head and adjust to height of studs.
- Remove valve springs with valve lever VW 541/1 and pressing piece VW 541/5.

Note:

Loosen tight valve cotters by lightly tapping lever VW 541/1 with hammer.

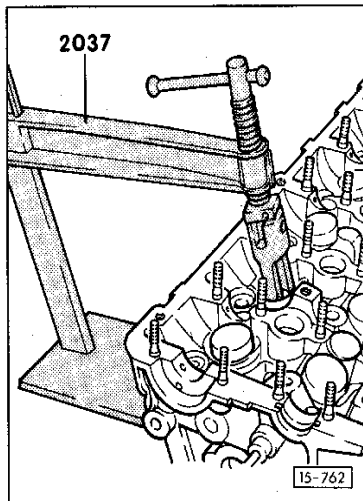

Exhaust side:

- ◀ - Remove valve springs with valve spring compressor 2037.

15-31

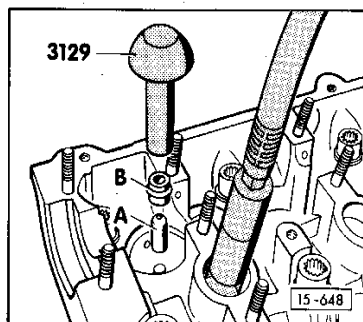

- Remove valve stem seals with puller 3047 A.
- ◀ - Fit plastic sleeve -A- onto valve stem. Oil valve stem seal -B-, insert into fitting tool 3129 and push down carefully onto valve guide.

Note:

To prevent damaging valve stem seal, always use plastic sleeve (included with valve stem seals).

15-32

REMOVING AND INSTALLING LUBRICATION SYSTEM COMPONENTS

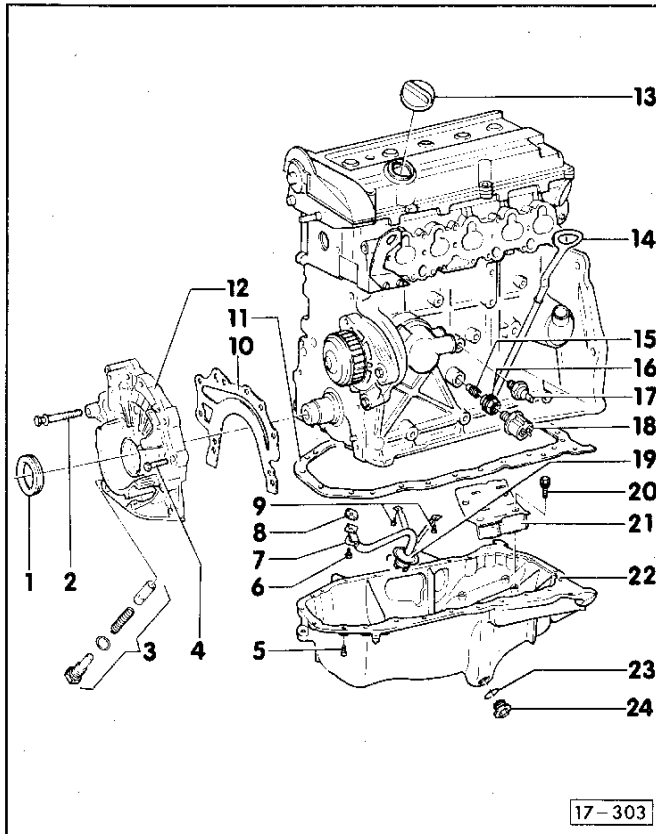

Note:

- o Lubricating system components shown in diagram can be removed and installed with engine installed.
- o If metal shavings and abrasion in large quantities - caused by scoring damage, such as piston, crankshaft or conrod bearing damage - are discovered in engine oil during engine repairs, crankcase and oil passages must be carefully cleaned in order to avoid further damage. Oil cooler must be checked for shavings and renewed if necessary - Page 17-7, item 27.
- o Oil spray jet for piston cooling - Page 13-31. Install bolt with locking compound D6 and tighten to 10 Nm.
- o Oil circuit capacity (with oil filter): 4.5 litres.

- 1- Oil seal
o Renew - see Repair Group 13
- 2- 20 Nm

17-1

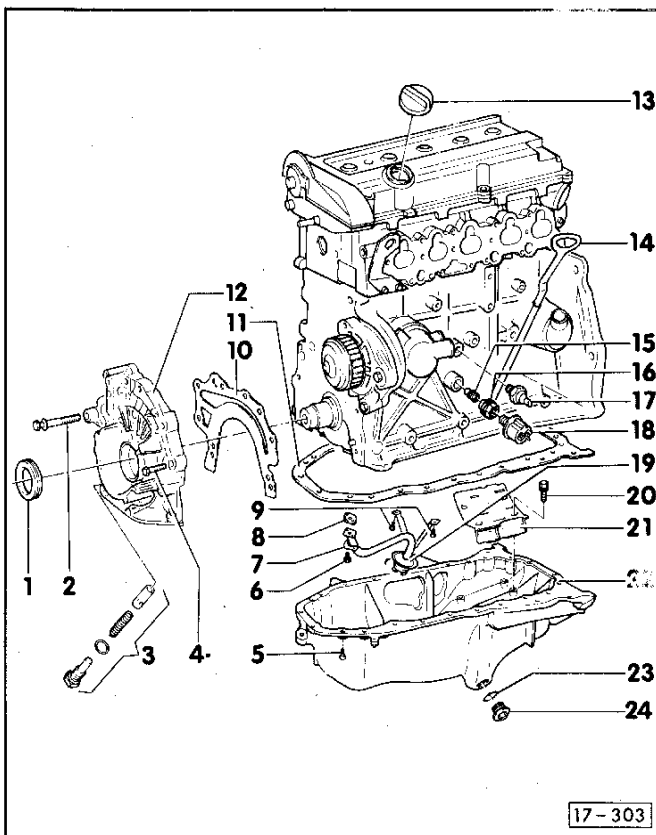

- 3- Oil pressure relief valve
o Measuring oil pressure - Page 17-9
o Threaded plug with sender for oil temperature gauge: 30 Nm
o Checking oil temperature gauge sender - Workshop Manual Audi 100 "Electrical System"
- 4- 10 Nm
- 5- 10 Nm for M6
20 Nm for M8
o When installing oil sump, tighten diagonally in two stages
- 6- 10 Nm
- 7- Securing plate
o Renew
- 8- Gasket
o Renew
o Do not bond.
- 9- 10 Nm
- 10- Oil pump gasket
o Renew
- 11- Gasket
o Renew

17-2

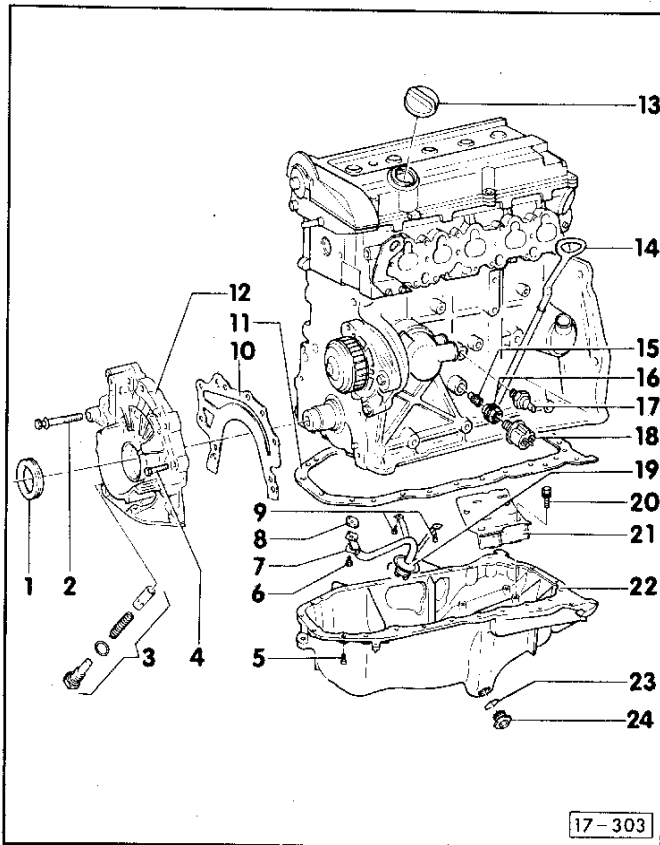

- 12- Oil pump
 - o Removing and installing - Page 17-14
 - o Only renew entire unit
- 13- Cap
 - o Renew seal if damaged
- 14- Oil dipstick
 - o Quantity difference Min. ... max.: 1.0 ltr.
- 15- Oil retention valve
 - o 6 Nm
 - o Remove and install with 8 mm four-square Allen key socket spanner
 - o Install with locking compound D6
- 16- Adapter
 - o 50 Nm
- 17- 1.8 bar oil pressure switch (white)
 - o 25 Nm
 - o Checking - Page 17-8
- 18- Oil pressure sender (-G10)
 - o 25 Nm
 - o Checking - Page 17-10
- 19- Suction pipe
 - o Attach to oil pump first

17-3

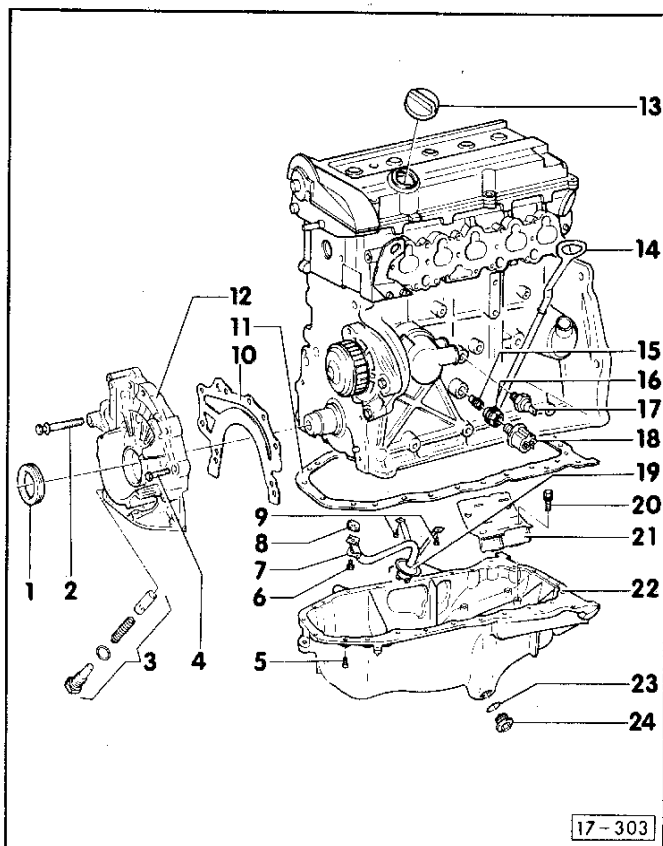

- 20- 10 Nm
- 21- Baffle plate
- 22- Oil sump
 - o Removing and installing - Page 17-12
 - o Clean sealing surface before mounting
- 23- Oil seal
 - o Renew
- 24- 30 Nm

17-4

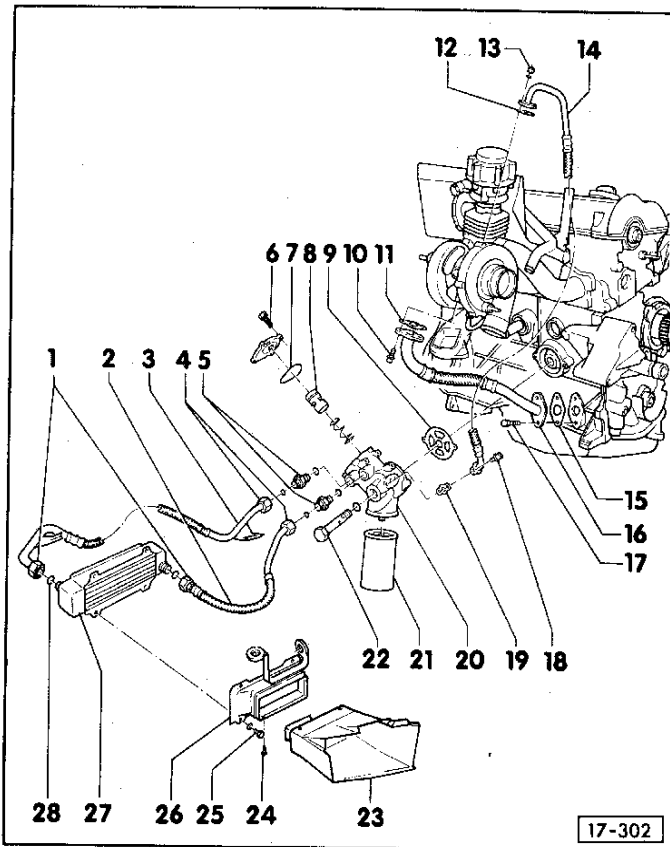

- 1- 40 Nm
- 2- Supply pipe
 - o For oil cooler
- 3- Return pipe
 - o For oil cooler
- 4- 40 Nm
- 5- Adapter
 - o 50 Nm
- 6- 10 Nm
- 7- Gasket
 - o Renew
- 8- Oil thermostat
 - o For oil cooler
- 9- Gasket
 - o Renew
- 10- 10 Nm
- 11- Gasket
 - o Renew
- 12- Gasket
 - o Renew
- 13- 10 Nm

17-5

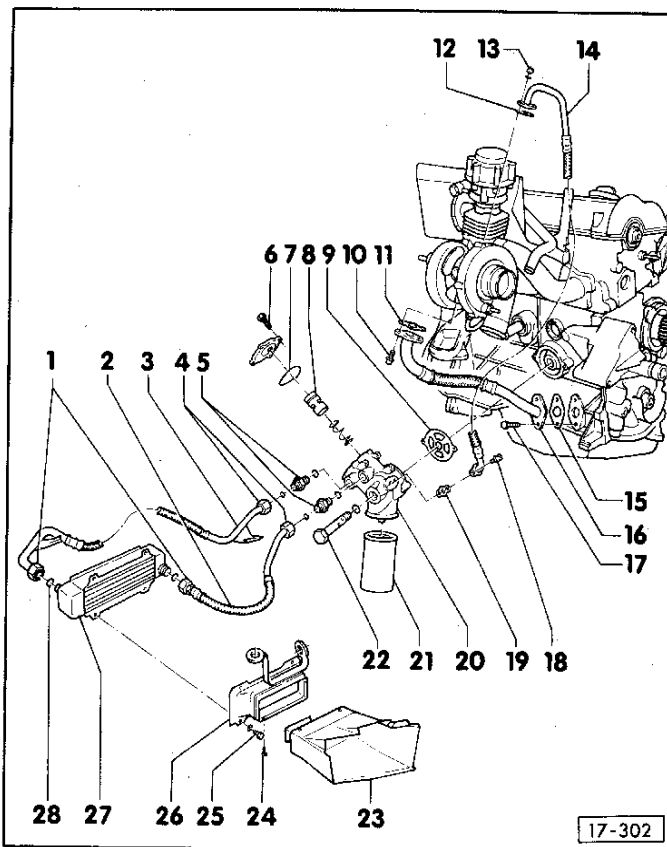

- 14- Oil supply pipe
 - o For turbocharger
- 15- Gasket
 - o Renew
- 16- Oil return pipe
 - o For turbocharger
- 17- 25 Nm
- 18- 10 Nm
- 19- Gasket
 - o Renew
- 20- Oil filter bracket
 - o With flange for oil pipe to turbocharger
 - o Installation position is fixed with alignment pins
- 21- Oil filter
 - o Tightening torque: 20 Nm
 - o Loosen and tighten with strap wrench
 - o Lightly oil seal
 - o Fill oil to normal level and start engine
 - o Check for leaks and retighten if necessary

17-6

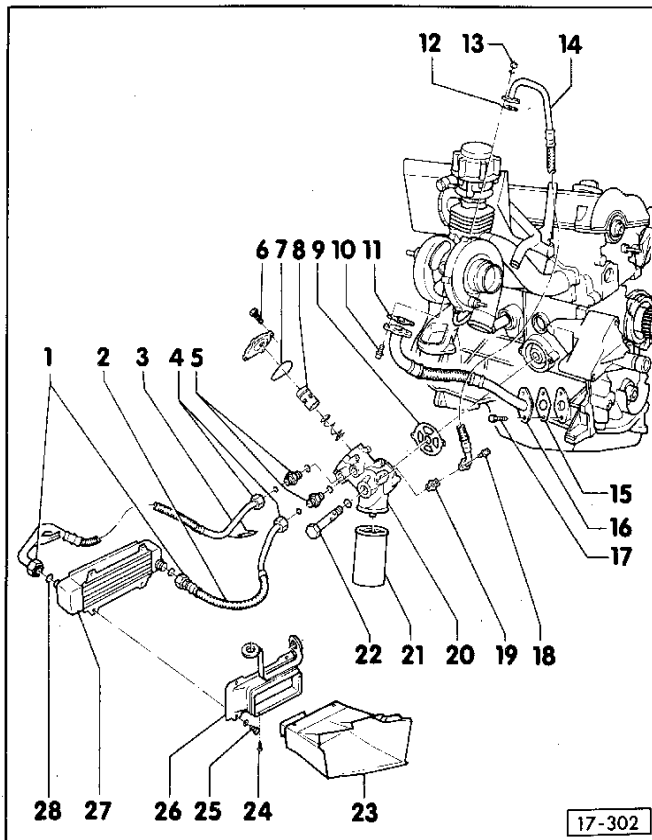

- 22- Banjo bolt
 - o 70 Nm
 - o With O-ring
- 23- Air duct
- 24- Self-tapping screw
 - o For securing air duct
- 25- 10 Nm
- 26- Oil cooler bracket
- 27- Oil cooler
 - o In case of engine damage, e.g. piston, crankshaft or conrod bearing damaged, check for metal shavings and renew if necessary - see note on Page 17-1
- 28- O-ring
 - o Renew

17-7

CHECKING OIL PRESSURE SWITCH AND OIL PRESSURE

Test conditions:

- o Oil level OK
- o Engine oil temperature at least 80 °C
- o Auto Check System OK (call up symbols)

Note:

Checking and servicing Auto Check System - see Workshop Manual Audi 100 "Electrical System".

Checking 1.8 bar oil pressure switch: (white insulation)

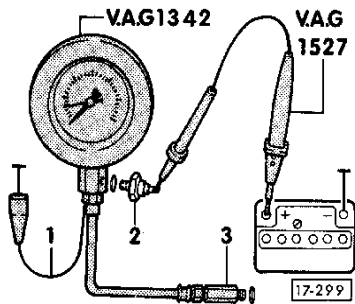

- ◀ - Remove oil pressure switch -2- and screw into oil pressure tester V.A.G 1342.
- Screw threaded connection -3- of oil pressure tester into cylinder block in place of oil pressure switch.
- Connect brown wire -1- of tester to earth.
- Connect diode test lamp V.A.G 1527 to battery positive (+) and to oil pressure switch in tester with auxiliary wires from V.A.G 1594 A.
- o Diode test lamp must not light up, otherwise renew oil pressure switch.
- ◀ Start engine and slowly increase speed.
- o At 1.6 ... 2.0 bar diode test lamp must light up, otherwise renew 1.8 bar oil pressure switch.

7-8

Checking oil pressure:

- Further increase engine speed.
- o At 2000 rpm and oil temperature of 80 °C, oil pressure must be at least 2.0 bar.
- Further increase engine speed.
Opening pressure of pressure relief valve:
3.0 ... 4.5 bar.
This pressure may be only minimally exceeded.

Note:

If oil pressure is excessive (pressure relief valve sticking or incorrectly installed), hydraulic tappets will be subjected to excessive pressure. Engine will cut out soon after starting and turn over noticeably fast during subsequent starting due to lack of compression.

17-9

CHECKING OIL PRESSURE SENDER (-G10)

Test conditions:

- o Oil level OK
- o Engine oil temperature at least 80 °C
- o Auto Check System OK (call up symbols)

Note:

- o Checking and servicing Auto Check System - see Workshop Manual Audi 100 "Electrical System".
- o Installation position of oil pressure sender (-G10) - Page 17-3, item 18.

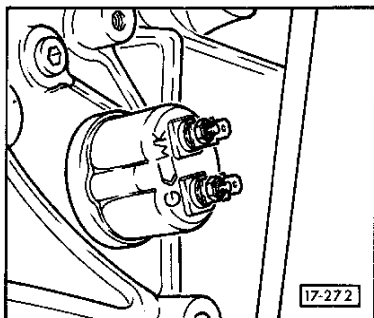

- ◀ - Pull wire off contact G of oil pressure sender (-G10).
- Connect hand multimeter V.A.G 1526 to contact G of oil pressure sender and engine earth with auxiliary wire from V.A.G 1594.
- Set V.A.G 1526 to 200 Ω measuring range (engine switched off).
Specified value: 5 ... 10 Ω
- Start engine and run at idle.
Specified value: 70 ... 120 Ω
- Increase engine speed to 3000 rpm.
Specified value: 170 ... 200 Ω

17-10

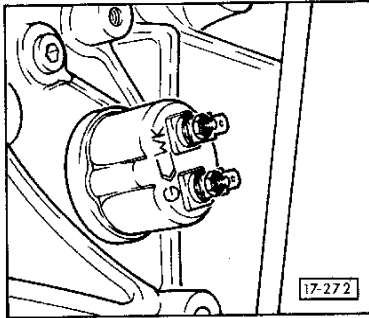

- ◀ - Pull off wire from contact WK of oil pressure sender (-G10).
- Connect hand multimeter V.A.G 1526 to contact WK of oil pressure sender and engine earth with auxiliary wire from V.A.G 1594.
- Run engine at idle.
Specified value: $\infty \Omega$
- Switch off engine.
Specified value: 0 ... 0.5 Ω
- If specified values are not obtained, renew oil pressure sender (-G10).

Note:

If wires of oil pressure sender are incorrectly connected, warning symbol (oil can) for engine oil pressure appears in Auto Check System.

17-11

REMOVING AND INSTALLING OIL SUMP

Removing:

- Pull out oil dipstick.
- ◀ - Unscrew retaining clips -arrows-.
- Unscrew wiring guide -1-.
- Unscrew two front bolts of subframe -2-.

Important!

When two front bolts of subframe are unscrewed, subframe drops down approx. 10 cm.

- Drain engine oil.
- There are two cutouts on flywheel cover and on flywheel.
- ◀ - Turn crankshaft until two securing bolts -arrows- of oil sump are visible.
- Remove oil sump.

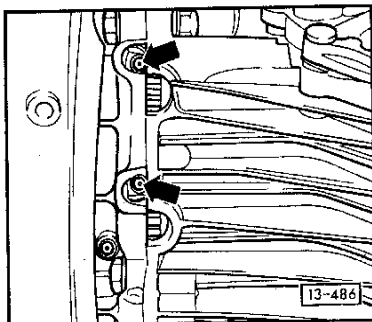
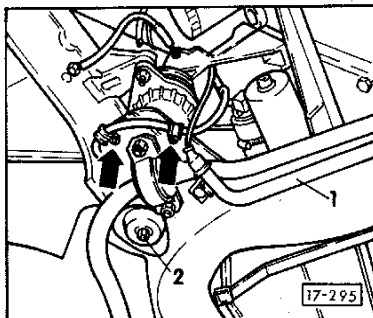

17-12

Installing:

- Renew gaskets.
- Renew subframe bolts.
Tightening torque: 110 Nm + 1/4 turn (90°).

17-13

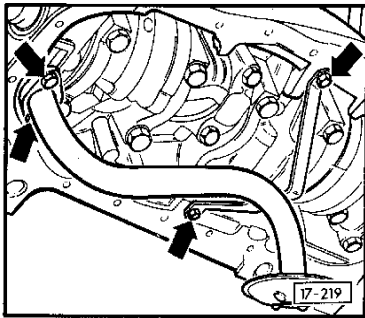

REMOVING AND INSTALLING OIL PUMP

Removing:

- Remove toothed belt - see Repair Group 13.
- Remove oil sump - Page 17-12.
- ◀ - Remove suction pipe.
- Unscrew oil pump and pull off crankshaft stub.

Installing:

- Renew gaskets.
- Fit sleeve from oil seal puller 2080 A to crankshaft journal to protect oil pump seal.
- When installing oil pump, make sure crankshaft drive gear engages.
- Install toothed belt - see Repair Group 13.

17-14

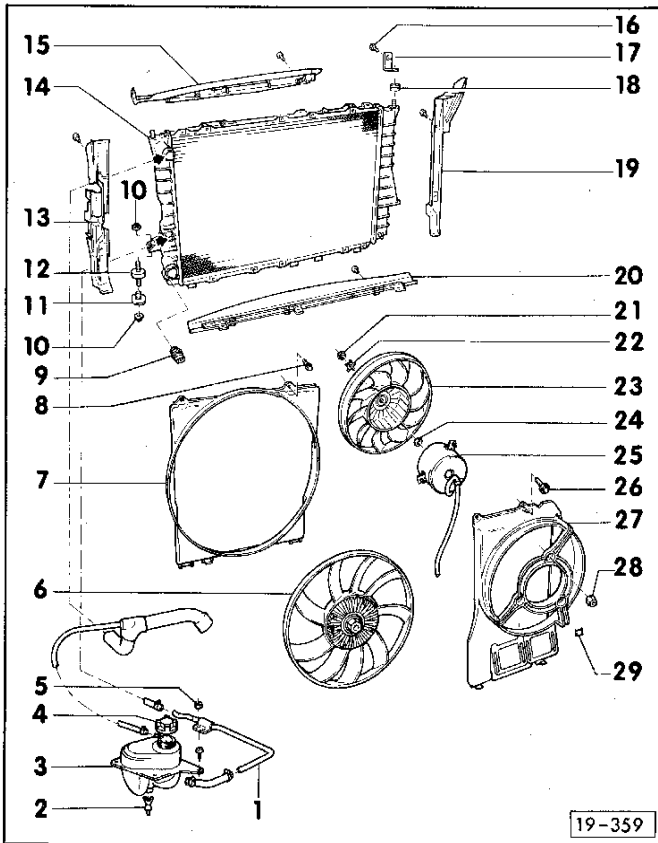

REMOVING AND INSTALLING COOLING SYSTEM COMPONENTS

- o Draining and refilling coolant - Page 19-10.
- o Checking coolant system for leaks - Page 19-14.

- 1- Coolant pipe
- 2- Connector
 - o For coolant shortage indicator switch -F66 in expansion tank
- 3- Expansion tank
 - o With coolant shortage indicator switch -F66
- 4- Cap
 - o Checking - Page 19-14
- 5- 10 Nm

19-1

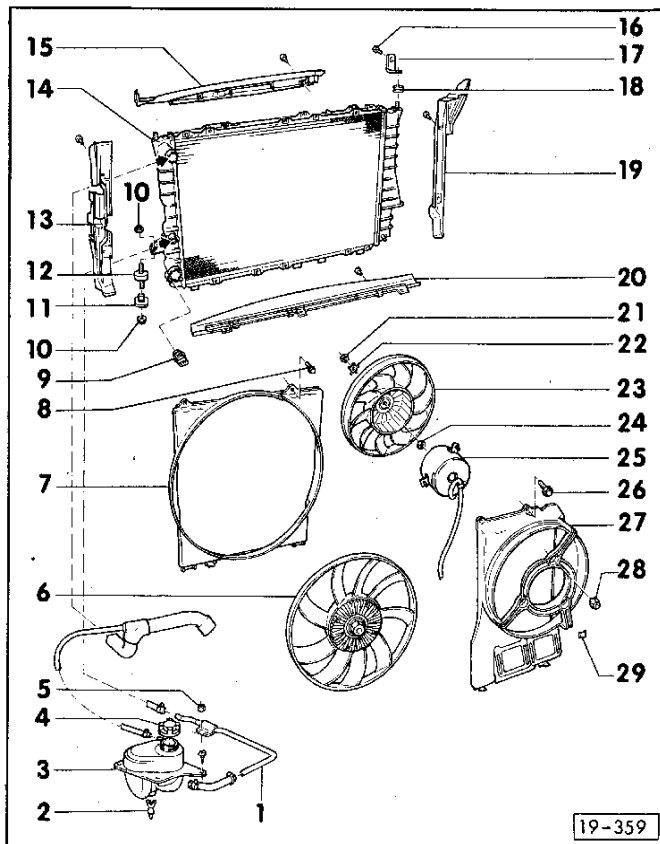

- 6- Fan with viscous clutch
 - o "FRONT" marking on outer fan ring must point in direction of travel
 - o Switching temperature 76 ± 4 °C Ambient temperature at viscous clutch
 - o Checking - Page 19-15
 - o Removing - see "Removing ribbed belt" - Repair Group 13
 - o Tightening torque of viscous clutch to bearing: 20 Nm
 - o Reverse threaded
- 7- Fan frame
- 8- 10 Nm
- 9- Thermoswitch for fan -F18 or -F54
 - o 25 Nm
 - o Switching temperatures:

1 = 1st stage	on 92 - 97 °C
	off 84 - 91 °C
2 = 2nd stage	on 99 - 105 °C
	off 91 - 98 °C
 - o + = Supply
- 10- 10 Nm
- 11- Packing
- 12- Bonded rubber bush
- 13- Left air guide

19-2

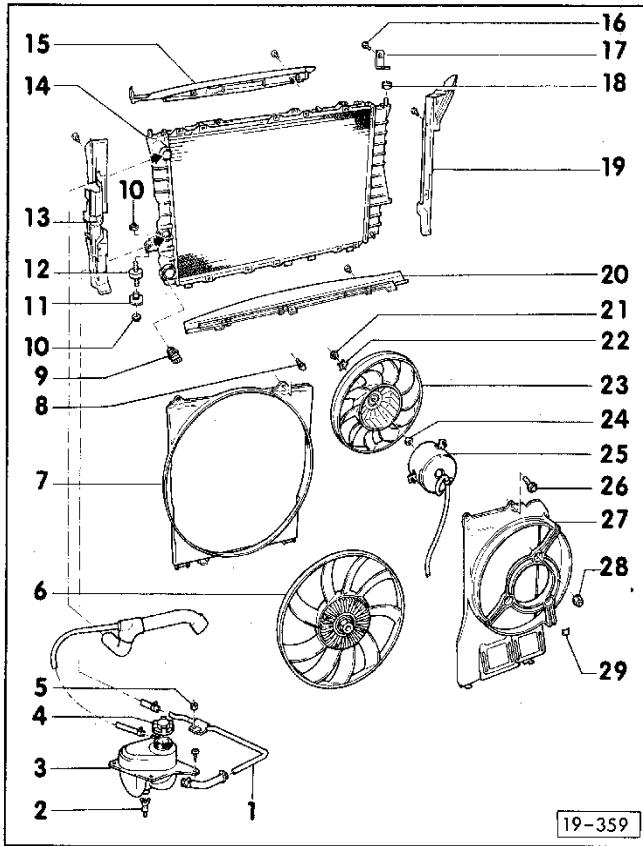

- 14- Radiator
 - o To remove, remove lock carrier plate and front bumper - see Workshop Manual Audi 100 "General Body Repairs", Repair Groups 50 and 63
 - o Lower coolant hose: Installation position - Fig. 1, Page 19-9

- 15- Upper air guide
- 16- 10 Nm
- 17- Angle bracket
- 18- Rubber grommet
 - o For angle bracket
- 19- Right air guide
- 20- Lower air guide
- 21- 10 Nm
 - o Important: Reverse-threaded!
- 22- Lock washer
 - o Grabs into fan
 - o Bend over one tooth to lock nut
- 23- Fan

19-3

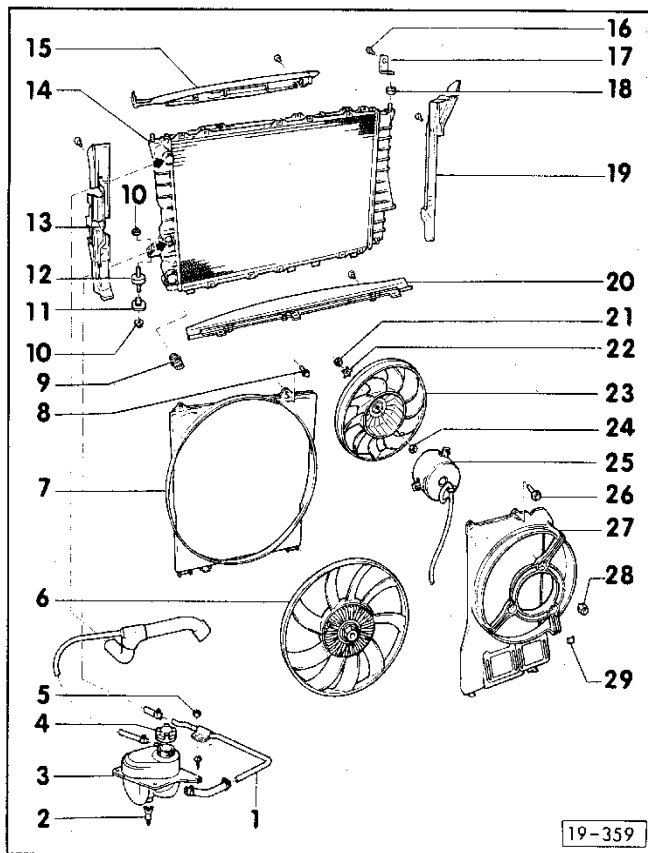

- 24- Washer
- 25- Fan motor
- 26- 10 Nm
- 27- Fan frame
 - o For electric fan
- 28- 10 Nm
- 29- Clip
 - o For wire to fan motor

19-4

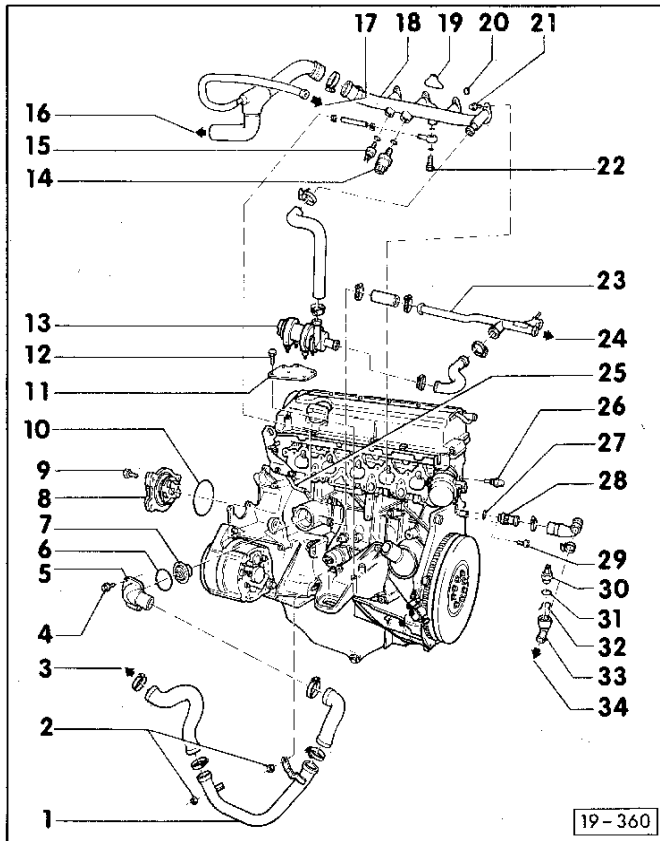

- 1- Coolant pipe
- 2- 20 Nm
- 3- To radiator (bottom)
 - o Installation position of lower coolant hose - Fig. 1, Page 19-9
- 4- 10 Nm
- 5- Union
- 6- O-ring
 - o For thermostat
 - o Renew
- 7- Thermostat
 - o Installation position - Fig. 2, Page 19-9
 - o Checking:
 - Heat thermostat in water
 - o Opens at approx. 87 °C
 - o Closes at approx. 102 °C
 - o Opening stroke at least 8 mm
- 8- Coolant pump
 - o Check shaft for ease of movement
 - o Renew coolant pump if damaged or leaking
- 9- 20 Nm

19-5

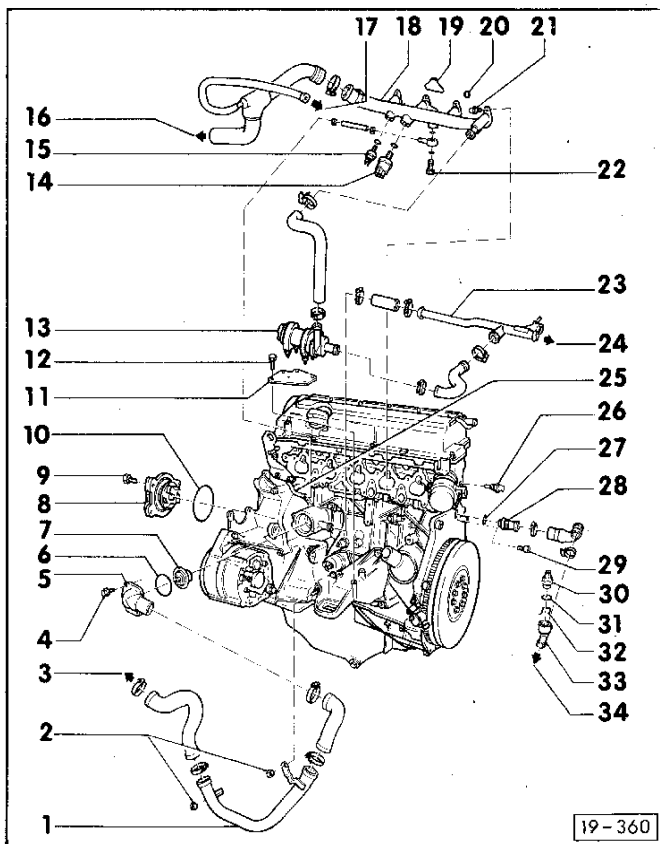

- 10- O-ring
 - o Renew
 - o Clean and smooth sealing surface for O-ring
- 11- Bracket for electric coolant pump
 - o Mounted on left Engine support
- 12- 20 Nm
- 13- Coolant pump
 - o For turbocharger
 - o Checking - Page 19-16
- 14- Electronic thermostat -F76
 - o Checking - see Workshop Manual Audi 100 "Electrical System"
 - o 25 Nm
- 15- Thermostat -F98
 - o For turbocharger coolant pump
 - o Switching temperatures:
 - on 106 - 112 °C
 - off 94 - 105 °C
 - o 15 Nm
 - o Checking - Page 19-16
- 16- To radiator (top)
- 17- To expansion tank

19-6

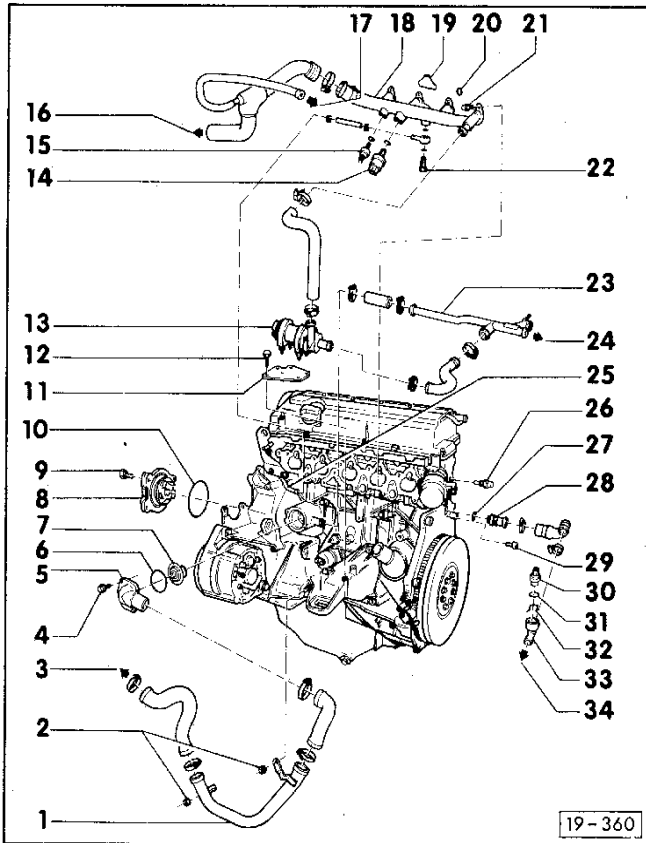

- 18- Coolant manifold
- 19- Gasket
o Renew
- 20- O-ring
o Renew
- 21- 10 Nm
- 22- Barjo bolt ~
o 30 Nm
- 23- Coolant pipe
- 24- From heater heat exchanger
- 25- Coolant supply pipe
o To turbocharger
- 26- Coolant temperature sender -G62
o 15 Nm
o Checking - see Workshop Manual Audi 100 "Motronic Ignition and Injection System"
- 27- O-ring
o Renew
- 28- Union
- 29- 20 Nm

19-7

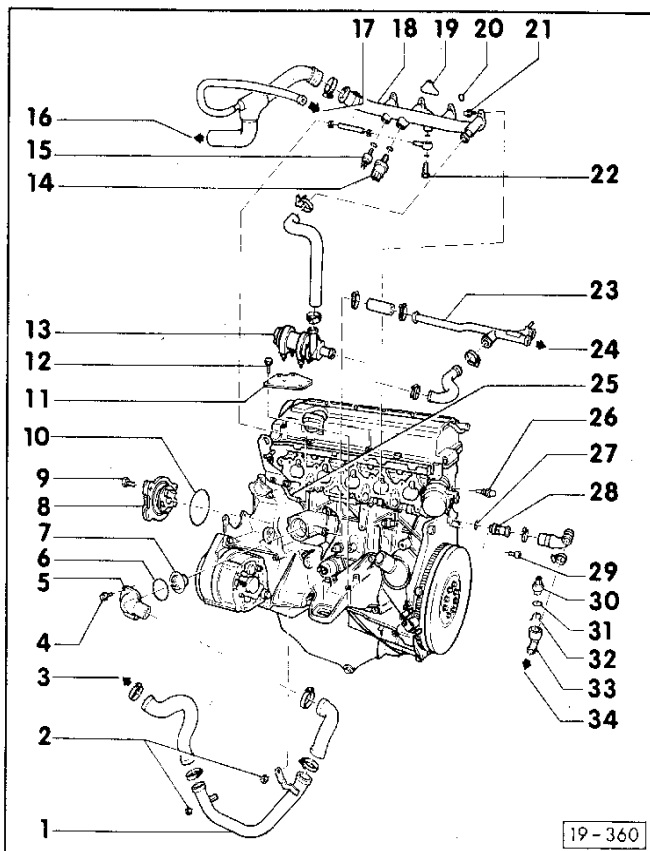

- 30- Sender for A/C coolant temperature -G110
o Checking - see Workshop Manual Audi 100 "Heater and Air Conditioner"
- 31- O-ring
o Renew
- 32- Retaining clip
- 33- Union
- 34- To heater heat exchanger

19-8

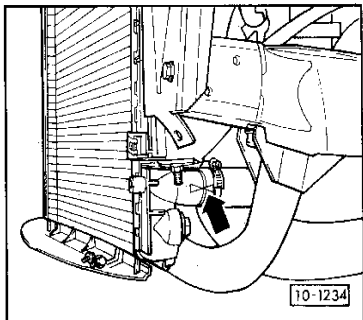

◀ Fig. 1 Installation position of bottom coolant hose

Arrow markings must be aligned.

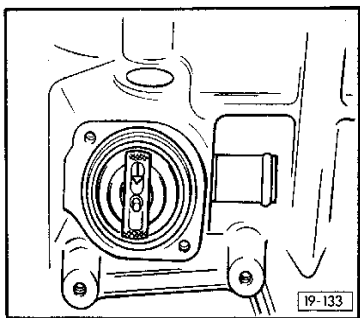

◀ Fig. 2 Thermostat installation position

19-9

DRAINING AND FILLING COOLANT

Note:

Cooling system is filled all year round with mixture of water and G11 V8 B antifreeze and anti-corrosion additive. G11 V8 B and coolant additives marked as being "in accordance with TL VW 774 B" prevent damage due to freezing, corrosion and scale formation. In addition, they raise cooling boiling point. For these reasons, coolant system must be filled all year round with anti-freeze and anti-corrosion additive.

Due to high boiling point, coolant is an aid to operational efficiency when engine is operating at full load - particularly in countries with tropical climates.

Recommended mixture ratios for 9.0 ltr. capacity:

Frost protection down to	G11 V8 B quantity	Water quantity
- 25 °C	3.6 ltr.	5.4 ltr.
- 35 °C ¹⁾	4.5 ltr.	4.5 ltr.

¹⁾ For countries with cold climates

19-10

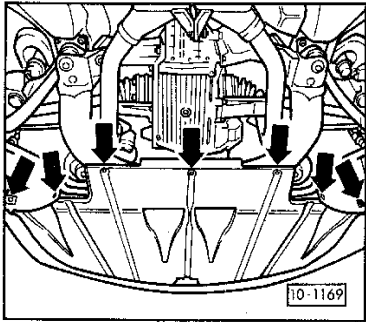

Draining:

Note:

Catch coolant for proper disposal.

- ◀ - Remove noise insulation.
- Position catch basin V.A.G 1306 under engine compartment.
- Open expansion tank cap.

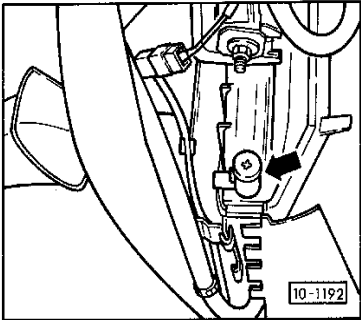

- ◀ - Drain coolant at radiator, pushing auxiliary hose onto drain cock if necessary.

19-11

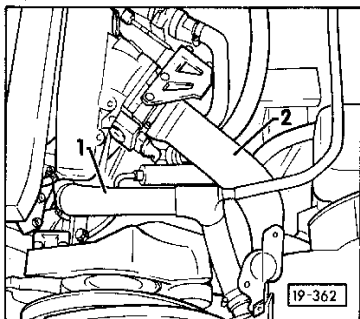

- ◀ - Remove upper hose to radiator -1- at radiator and coolant manifold and lay aside. T-piece to expansion tank remains connected.
- Remove air hose -2-.

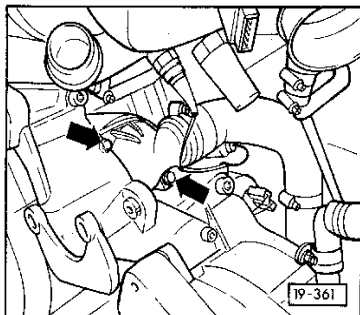

- ◀ - Remove union -arrows-.
- Take off O-ring and thermostat, allowing remaining coolant to run off.

19-12

Filling:

o Renew coolant.

- Install thermostat with new O-ring - installation position - Fig. 2, Page 19-9.

- Fit union (10 Nm).

- Install coolant hose.

◀ - Fill coolant up to upper edge of expansion tank.

- Close expansion tank.

- Run engine until operating temperature has been reached (coolant temperature gauge at approx. 80 °C).

- Check coolant level and top up to marking if necessary. When engine is at operating temperature, coolant level must be somewhat above "MAX" mark. When engine is cold, level must lie between "MIN" and "MAX" marking.

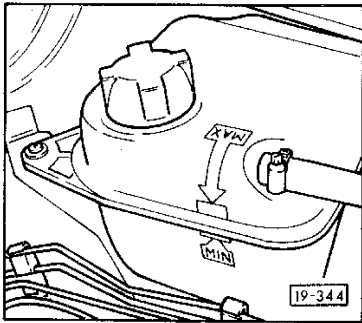

19-13

CHECKING COOLANT SYSTEM FOR LEAKS

o Carry out only when engine is at operating temperature.

◀ - Fit cooling system tester VW 1274 to expansion tank with adapter VW 1274/1.

- Produce pressure of approx. 1.0 bar with hand pump of tester.

- If pressure drops within short time, locate leak and repair.

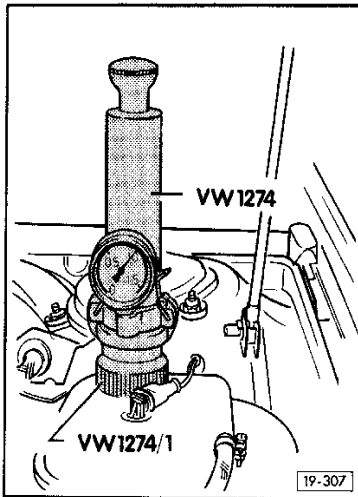

CHECKING PRESSURE RELIEF VALVE IN CAP

◀ - Screw cap onto cooling system tester VW 1274 with adapter VW 1274/1.

- Produce pressure with hand pump of tester.

- Pressure relief valve must open at 1.2 ... 1.5 bar.

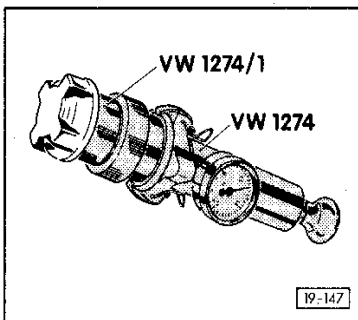

19-14

CHECKING VISCOUS FAN

Visual check:

- Check viscous clutch for oil leaks. Backside of clutch housing must be clean and dry.
- Check ease of movement of fan with engine switched off. It must be possible to turn fan without noticeable resistance.
- Check axial clearance. Clearance should be measured at outer circumference of fan - not exceed approx. 15 mm.

Note:

- o Function of viscous fan clutch cannot be checked in workshop.
- o When renewing viscous clutch, watch installation position of fan - Page 19-1.

19-15

CHECKING TURBOCHARGER THERMOSWITCH -F98 AND COOLANT PUMP

- Run engine until coolant temperature gauge indicates more than 100 °C (cover radiator if necessary).
- Switch off engine.
- After approx. 5 minutes, electric coolant pump and radiator fan must switch on.
- o If electric coolant pump and radiator fan do not run:
 - Disconnect wires to thermoswitch and connect to each other.
 - Electric coolant pump and radiator fan must run.
- o If coolant pump and radiator fan run:
 - Renew thermoswitch.
- o If coolant pump and radiator fan do not run:
 - Eliminate fault using current flow diagram.

19-16

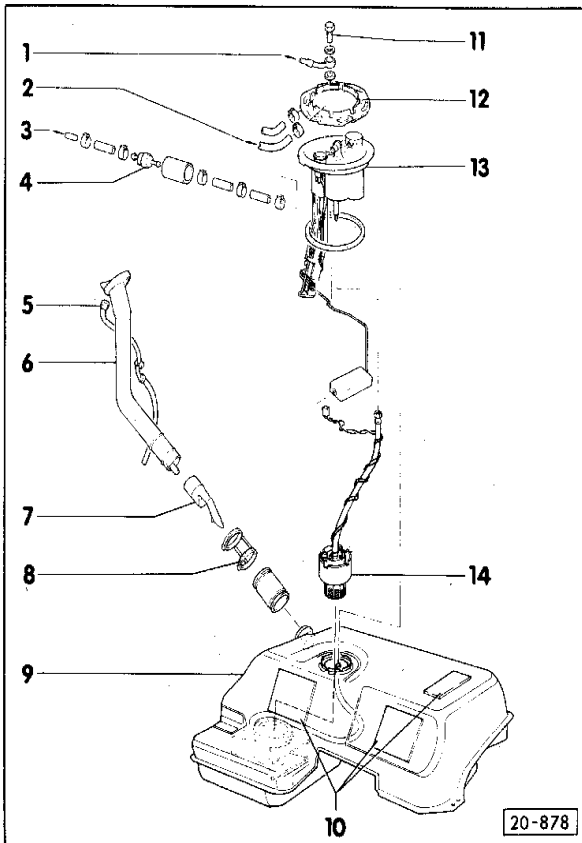

REMOVING AND INSTALLING FUEL SYSTEM COMPONENTS

Important!
When working on fuel system, respectively valid safety rules must be observed.

Note:

- o Always renew gaskets, oil seals and hose clips during repair work.
- o Hose connections are secured with screw or spring clips.
- o Connect remote control - Fig. 1, Page 20-3
- o Checking fuel pump relay - see Workshop Manual Audi 100 "Motronic Injection and Ignition System".
- o When removing and installing fuel gauge sender, make sure that wires are not damaged.
- o Observe rules for cleanliness - Page 20-4

- 1- Supply pipe
 - o To fuel tank
 - o Installation position of fuel filter - Fig. 2, Page 20-3
- 2- Return pipe

20-1

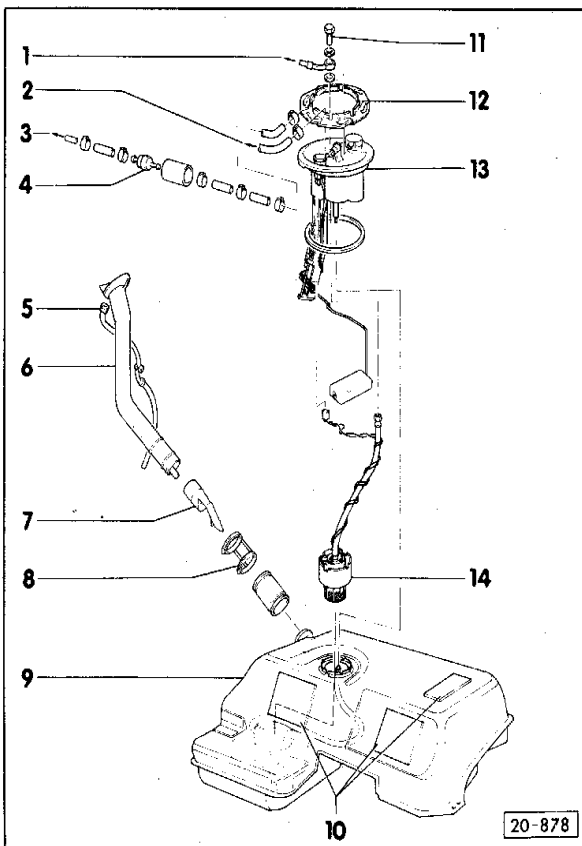

- 3- Breather pipe
 - o To activated charcoal filter
- 4- Pressure holding valve
 - o 0.02 ... 0.3 bar
 - o Prevents fuel from reaching activated charcoal filter if tank is overfilled
- 5- Overflow pipe
- 6- Filler pipe
- 7- Non-return flap
- 8- Double clip
- 9- Fuel tank
 - o Removing and installing - Page 20-11
- 10- Packing
 - o Prevent rubbing
- 11- Banjo bolt
 - o 20 Nm
- 12- Locking ring
 - o Removing - Page 20-7
- 13- Fuel gauge sender
 - o Removing and installing - Page 20-6
- 14- Fuel pump

20-2

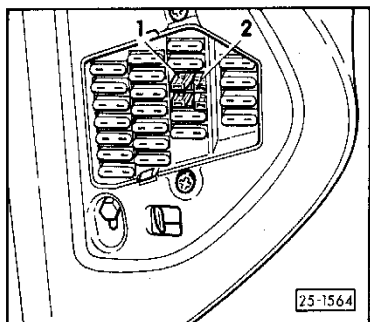

◀ Fig. 1 Connecting remote control V.A.G 1348/3 A with adapter wire V.A.G 1348/3-2

- Pull fuse No. 17 out of fuse holder.
- Connect remote control V.A.G 1348/3 A to contact of fuse socket of fuse No. 17 (item 2) with adapter wire V.A.G 1348/3-2 and auxiliary wires from V.A.G 1594.
- Connect clip terminal to battery (+).

On vehicles with air conditioner:

- Connect clip terminal to starting aid socket (+).

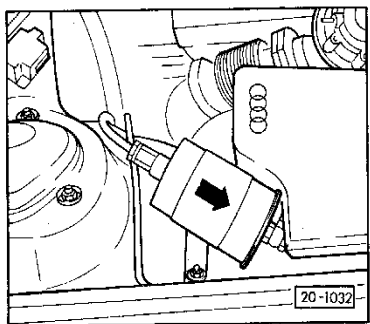

◀ Fig. 2 Installation position of fuel filter

Arrow = Direction of flow to engine.

20-3

RULES FOR CLEANLINESS WHEN WORKING ON FUEL SUPPLY/INJECTION SYSTEM

- o Thoroughly clean all unions and surrounding areas before disconnecting.
- o Place removed parts on clean surface and cover with film or paper. Do not use fluffy cloths!
- o Carefully cover or seal opened components if repairs cannot be carried out immediately.
- o Only install clean parts.
 - Only unpack replacement parts immediately prior to installation.
 - Do not use parts that have been stored loose (e.g. in toolboxes etc.)
- o When fuel system is opened:
 - Do not work with compressed air if avoidable.
 - Do not move vehicle unless absolutely necessary.

20-4

SAFETY MEASURES WHEN WORKING ON FUEL TANK

When removing and installing fuel pump or fuel gauge sender from completely or partially filled fuel tank, the following must be observed:

- o Before beginning repairs, suction pipe of exhaust extraction unit must be located near repair opening of fuel tank so that fuel vapours which escape after opening cap can be immediately sucked off.
If no exhaust extraction unit is available, a radial fan (motor is located outside airflow) with volume of more than 15 m³/hr. may be used.
- o If it is necessary to reach into fuel when removing or installing fuel pump, fuel resistant gloves must be worn.

20-5

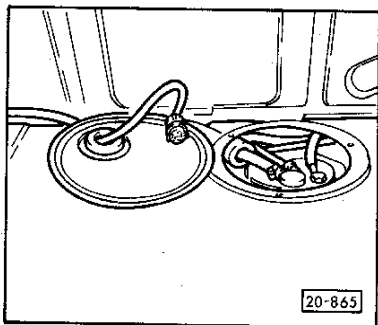

REMOVING AND INSTALLING FUEL GAUGE SENDER

- o Observe safety measures - Page 20-5.

Important!
Fuel tank must not be more than 2/3 full.

Removing:

- ◀ - Remove cover (under luggage boot floor covering).
- Pull off connector for fuel gauge and fuel pump.
- ◀ - Loosen clips of supply pipe -A-, return pipe -B- and breather pipe -C- and pull off pipes.
- Note installation position of fuel gauge sender - mark if necessary.

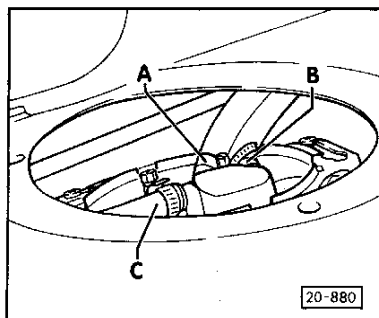

20-6

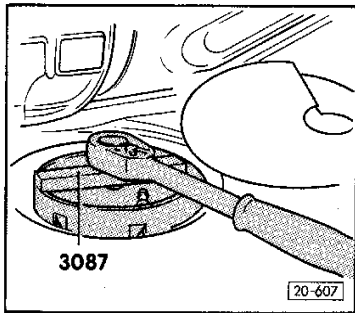

- ◀ - Unscrew locking ring with spanner for sender 3087 and pull sender out of fuel tank.

Note:

When removing and installing fuel tank sender, ensure that wires are not damaged.

- Pull supply and return pipes off inner side of sender housing.
- Pull off electrical connection to fuel pump.

Installing:

- Watch installation position of fuel gauge sender.

20-7

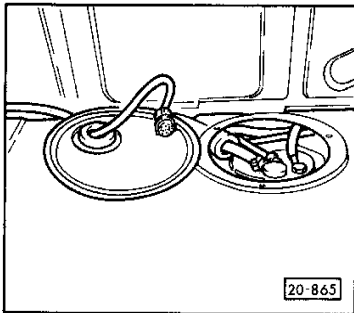

REMOVING AND INSTALLING FUEL PUMP

- o Observe safety measures - Page 20-5.

Important!

Fuel tank must not be more than 2/3 full.

Removing:

- ◀ - Remove cover (under luggage boot floor covering).
- Pull off connector for fuel gauge and fuel pump.

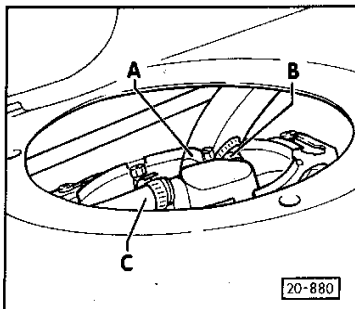

- ◀ - Loosen clips of supply pipe -A-, return pipe -B- and breather pipe -C- and pull off pipes.
- Note installation position of fuel gauge sender - mark if necessary.

20-8

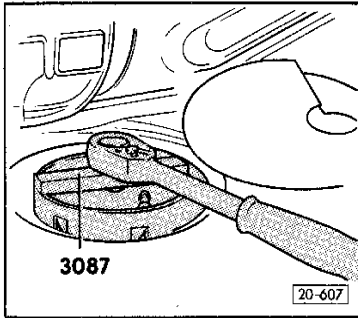

- ◀ - Unscrew locking ring with spanner for sender 3087 and pull sender out of fuel tank.

Note:

When removing and installing fuel tank sender, ensure that wires are not damaged.

- Pull supply and return pipes off inner side of sender housing.
- Pull off electrical connection to fuel pump.

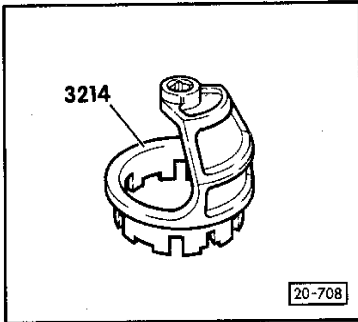

- ◀ - Fit fuel pump spanner 3214 to fuel pump in baffle housing and turn pump approx. 15 mm toward left.
- Pull out pump upward.

20-9

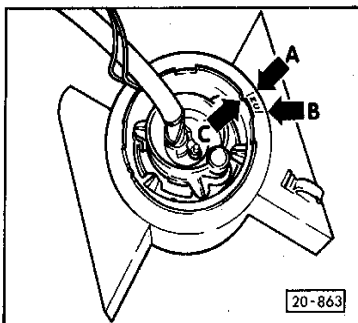

Installing:

- ◀ - Insert fuel pump into baffle housing so that V-marking -C- aligns with marking -A-.
- Fit fuel pump spanner 3214 to fuel pump.
- Turn fuel pump clockwise until V-marking -C- aligns with marking -B- (fuel pump engages).
- Match installation position of fuel gauge sender.

20-10

REMOVING AND INSTALLING FUEL TANK

Removal instructions:

- Empty fuel tank before removing with fuel extractor V.A.G 1433/A.
- Remove cover in plenum chamber at right and disconnect battery earthing strap. (On vehicles with fresh air filter or air conditioner, battery is located under rear seat cushion.
- Remove rear final drive - see Workshop Manual Audi 100 "5-Speed Manual Gearbox 01A 4-Wheel Drive" - Repair Group 39.
- To support, position engine/gearbox lifter V.A.G 1383 A under fuel tank.

Installation instructions:

- Attach insulating strips and pipe attachments on new fuel tank using removed tank as a guide.
- Install rear final drive - see Workshop Manual Audi 100 "5-Speed Manual Gearbox 01A 4-Wheel Drive" - Repair Group 39.

20-11

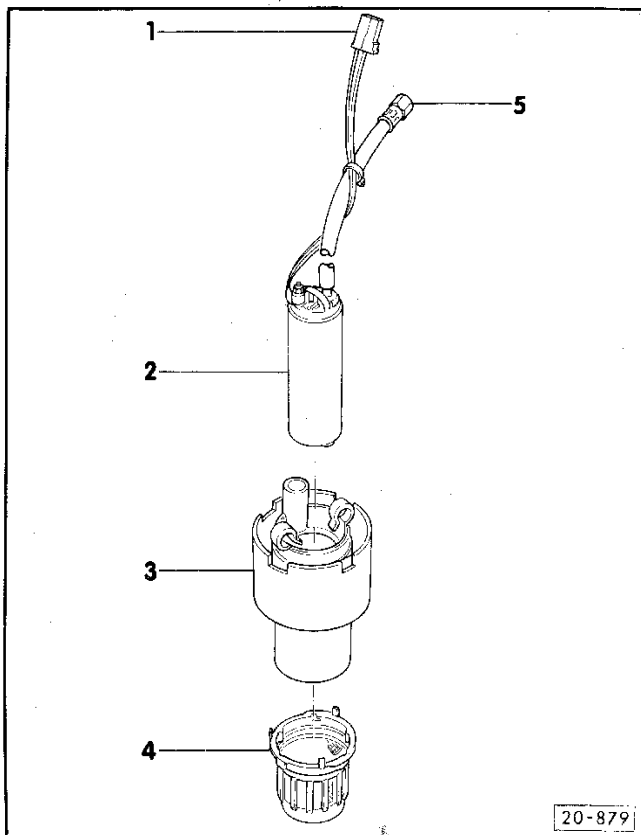

DISMANTLING AND ASSEMBLING FUEL PUMP

Note:

- There are two baffle housing versions:
- a- Baffle housing connected to filter screen with bayonet fitting.
 - b- Baffle housing welded to filter screen.

- 1- Electrical connection
o For fuel pump
- 2- Fuel pump
- 3- Baffle housing
- 4- Filter screen
- 5- Supply pipe

20-879

20-12

CHECKING FUEL PUMP

Checking power supply

- o Battery fully charged (at least 12 V)
- o fuel filter in good condition
- Connect remote control V.A.G 1348/3 A - Fig. 1, Page 20-5.
- Operate remote control. Fuel pump must operate audibly.

Note:

In noisy surroundings, second mechanic may be required to listen for pump operating noises under vehicle near fuel tank.

o fuel pump runs:

- Check fuel pump relay - see Workshop Manual Audi 100 "Motronic Injection and Ignition System", Repair Group 01.

o Fuel pump does not run:

- ◀ - Unscrew cover for fuel gauge sender and fuel pump (under luggage boot floor covering).
- Pull off connector for fuel pump and fuel gauge.

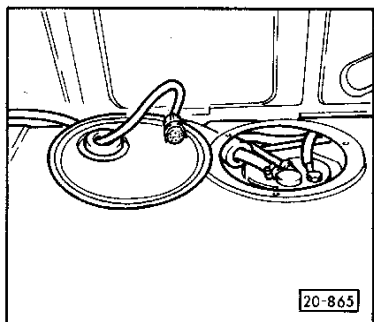

20-13

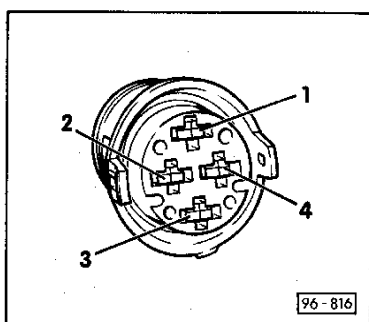

- ◀ - Connect hand multimeter V.A.G 1526 to contacts 1 (green/yellow) and 4 (brown) with auxiliary wires from V.A.G 1594.

- Operate remote control.

Specified value: approx. battery voltage

o If specified value is not obtained:

- Eliminate break in wiring using current flow diagram.

o If specified value is obtained:

- Remove fuel gauge sender - Page 20-6.

- ◀ - Check wires from sender housing to fuel pump for continuity with hand multimeter and auxiliary wires.

- Eliminate break in wiring if necessary.

- If no break in wiring is present, renew fuel pump. Removing and installing fuel pump - Page 20-8.

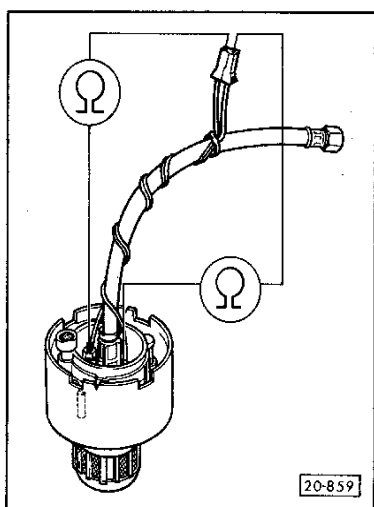

20-14

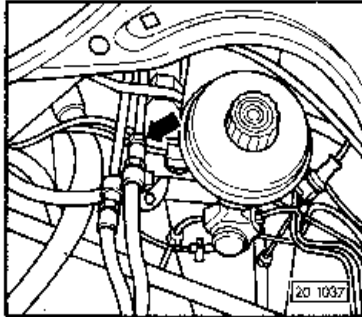

Checking feed rate

- ◀ - Unscrew supply pipe (upper pipe) -arrow-

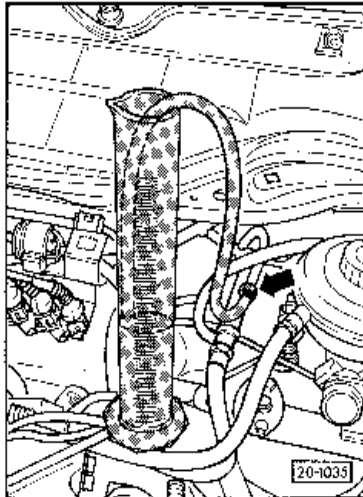

- ◀ - Attach hose to supply pipe and hold in measuring glass.

20-16

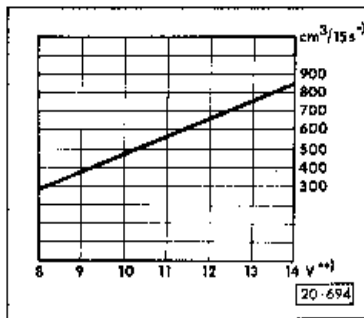

- Operate remote control V.A.G 1348/3 A * for 15 seconds (hold down button).

- ◀ - Compare measured quantity with specified values for minimum feed rate in graph.

* Minimum feed rate measured at return pipe is cm³/15 sec.

** Voltage at fuel pump with engine stopped and pump running (approx. 2 V below battery voltage).

20-16

CHECKING NON-RETURN VALVE OF FUEL PUMP

Test conditions:

- o Pressure regulator, fuel pump, injectors and fuel filter OK
- o Wiring system OK
- o Feed rate of fuel pump OK, checking - Page 20-15
- o Battery fully charged (at least 12 V)

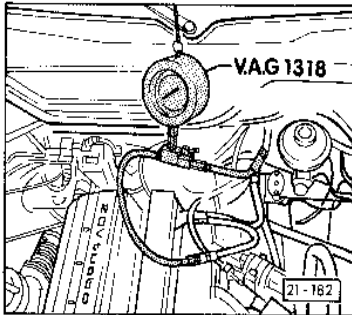

- Connect remote control V.A.G 1348/3 A with adapter wire V.A.G 1348/3-2 - Fig. 1, Page 20-5.

- ◀ - Connect pressure gauge V.A.G 1318 between fuel supply and fuel collector pipes with adapter V.A.G 1318/11, V.A.G 1318/13 and V.A.G 1318/15. Lever to pressure gauge in "open" position.

- Operate remote control for approx. 30 seconds.

- Move lever on pressure gauge to "closed" position.

Note:

Pressure gauge lever must remain in "closed" position during measuring procedure.

20-17

- Briefly operate remote control until max. 5.5 bar is indicated.

- Watch pressure drop:

after 10 min.: max. 0,5 bar

If pressure drop is greater, carry out following checks:

- Check pressure gauge connections for leaks.
 - o Check fuel lines for leaks.
- If no leaks are present, non-return valve in fuel pump is defective.
- Renew fuel pump - Page 20-8.

20-18

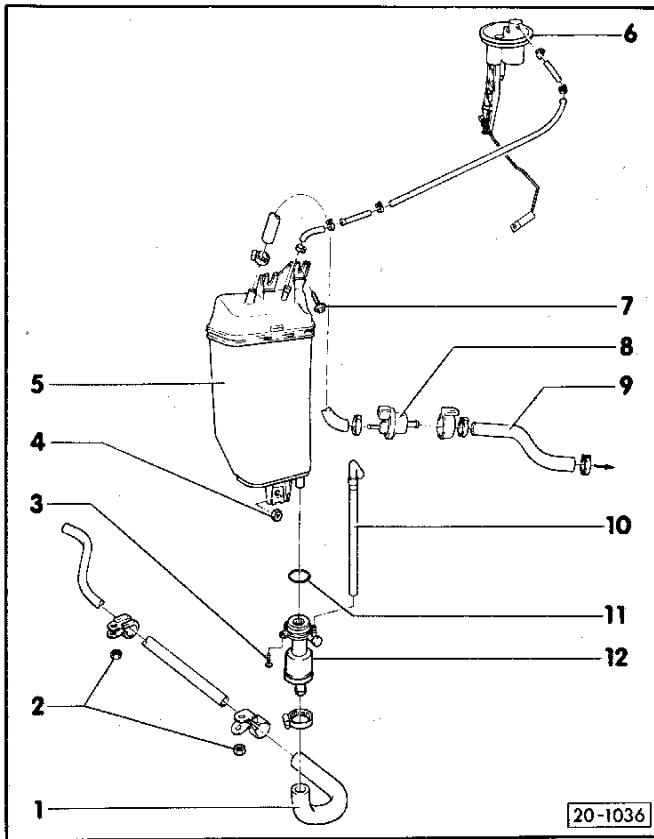

SERVICING FUEL TANK VENTILATION WITH ACTIVATED CHARCOAL FILTER

- 1- Hose
 - o Ends in open on right-hand side of vehicle floor pan
- 2- 10 Nm
- 3- Self-tapping screw
 - o For ventilation valve
- 4- 10 Nm
- 5- Activated charcoal filter (ACF)
 - o Installation position: front right wheel housing:
 - o Hose connections - Fig. 1, Page 20-21
- 6- Fuel gauge sender
- 7- Self-tapping screw
- 8- Solenoid valve for activated charcoal filter
 - o Checking function and actuation - see Workshop Manual Audi 100 "Motronic Ignition and Injection System"

20-19

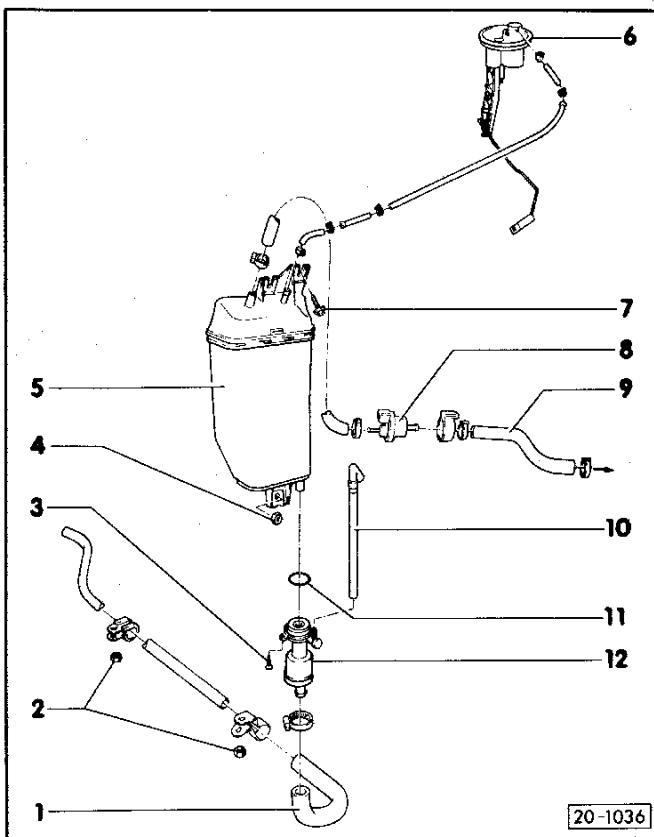

- 9- Hose
 - o To throttle housing
- 10- Hose
 - o Hook into clip on activated charcoal filter
- 11- Sealing ring
 - o Renew
- 12- Ventilation valve
 - o Regulates ventilation of activated charcoal filter
 - o Prevents splash water from reaching activated charcoal filter

20-20

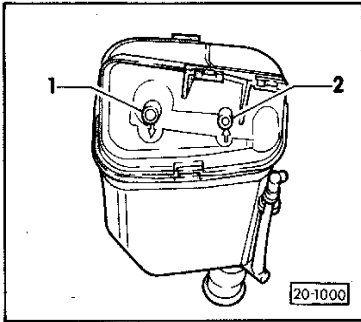

◀ Fig. 1 Hose connections of activated charcoal filter

- 1- To solenoid valve for activated charcoal filter.
- 2- To fuel gauge sender.

20-21

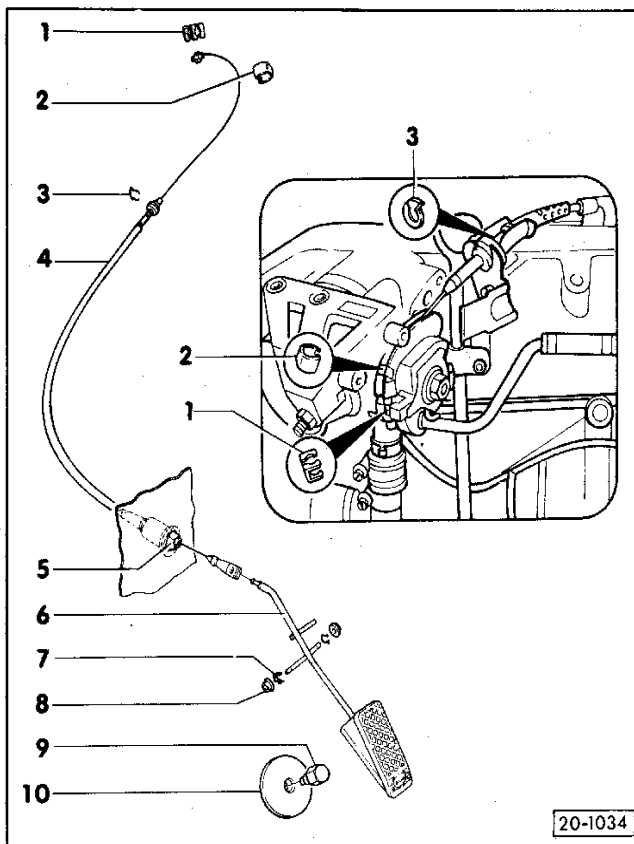

SERVICING THROTTLE LINKAGE

- 1- Clip
- 2- Locking clip
- 3- Locking clip
o For adjusting throttle cable
- 4- Throttle cable
o Adjusting - Page 20-23
- 5- Square bearing
- 6- Throttle pedal
- 7- Locking clip
- 8- Bearing sleeve
- 9- Stop bolt for throttle pedal
- 10- Washer

20-22

ADJUSTING THROTTLE CABLE

Note:

- o Throttle cable is highly susceptible to kinking and must therefore be carefully handled when installing.
- o Single, slight kink can lead to break later. Therefore, throttle cable which has been kinked may not be installed.
- o When installing, ensure that throttle cable aligns between support bracket and fast idle cam.

Adjustment conditions:

- o Throttle cable connected to throttle pedal and fast idle cam.
 - o Securing clip pulled off throttle cable sleeve.
-
- Depress throttle pedal to full throttle position.
 - Pull back throttle cable sleeve until throttle valve lever contacts full throttle stop.
 - Insert securing clip behind support bracket at locking segment of throttle cable sleeve.

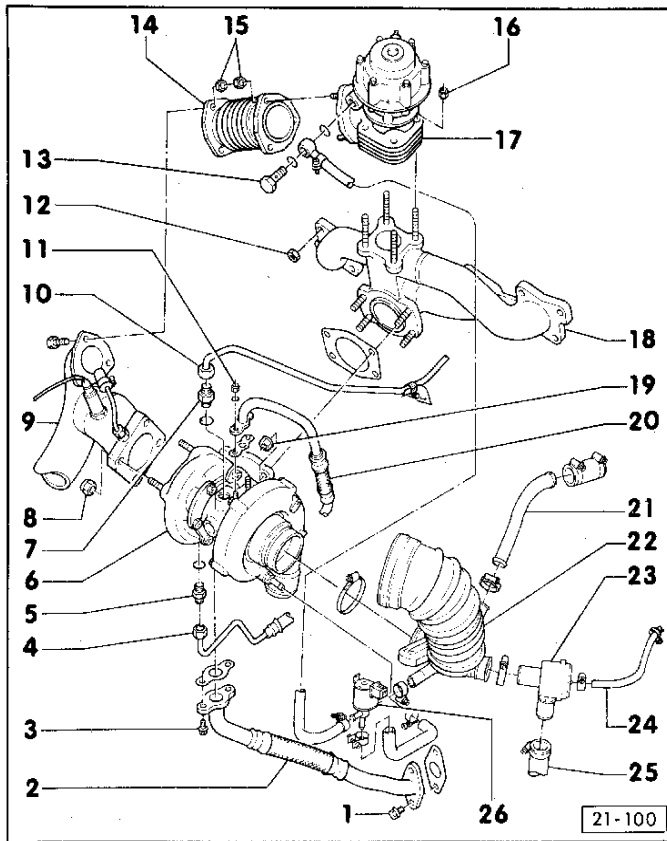

REMOVING AND INSTALLING TURBOCHARGER COMPONENTS

Note:

- o Observe rules for cleanliness - Page 21-4.
- o Hose connections are secured with clips.
- o Always renew seals.
- o Filling turbocharger with oil - Page 21-9.

- 1- 10 Nm
- 2- Oil return pipe
- 3- 10 Nm
- 4- Coolant return pipe
 - o 25 Nm
 - o Seal with appropriate plug after unscrewing
- 5- Adapter
 - o 30 Nm
- 6- Turbocharger
 - o Checking - Page 21-10
 - o Removing and installing - Page 21-5
- 7- Adapter
 - o 35 Nm

21-1

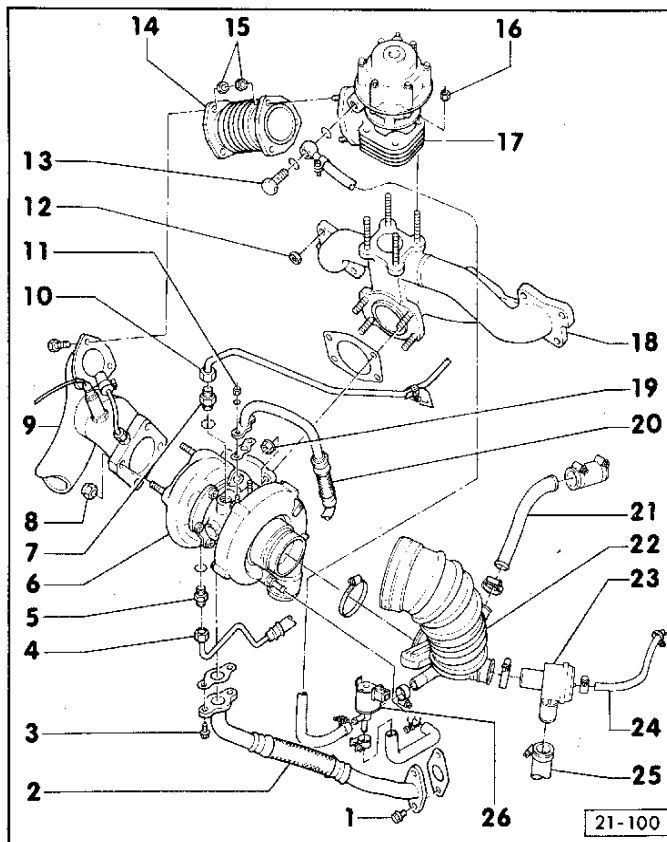

- 8- 40 Nm
 - o Renew
- 9- Exhaust down pipe
 - o Removing and installing - see Repair Group 26
- 10- Coolant supply pipe
 - o 30 Nm
 - o Seal with appropriate plug after unscrewing
- 11- 10 Nm
- 12- 25 Nm
 - o Renew
- 13- Banjo bolt
 - o 25 Nm
- 14- Corrugated pipe
 - o Watch installation position - see Repair Group 26
- 15- 25 Nm
 - o Renew
- 16- 25 Nm
 - o Renew
- 17- Waste gate
 - o Checking - Page 21-10
 - o Removing and installing - Page 21-6
- 18- Exhaust manifold

21-2

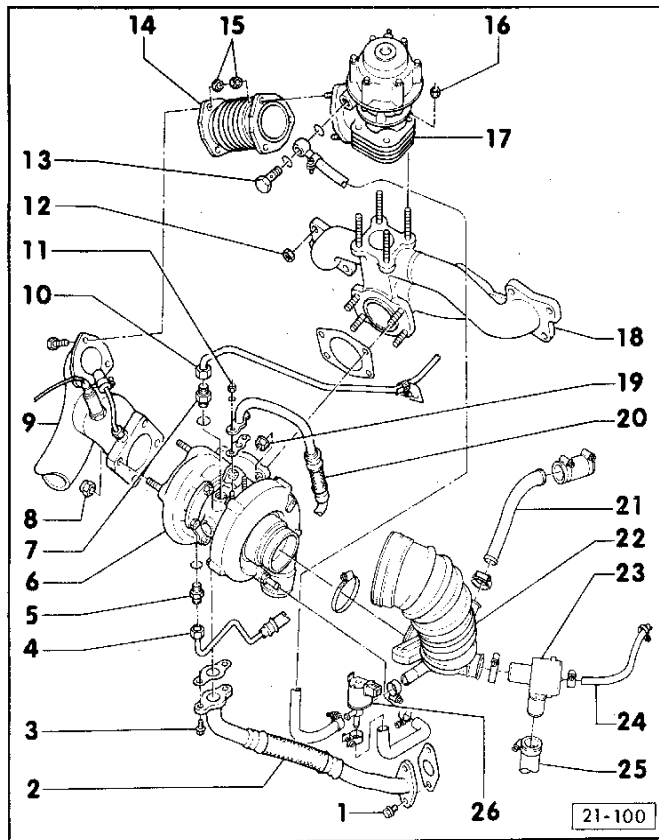

- 19- 60 Nm
o Renew
- 20- Oil supply pipe
o Before screwing on, fill oil hole on turbocharger with engine oil - Page 21-9
- 21- Hose
o For crankcase ventilation
o To cylinder head cover
- 22- Air hose
o To air volume sensor
- 23- Overrun cut-off valve
o Checking - Page 21-13
- 24- Vacuum hose
o Via connecting pipe to intake manifold
- 25- Hose
o To pressure pipe
- 26- Solenoid valve for boost pressure limiting -N75
o Checking - see Workshop Manual Audi 100 "Motronic Ignition and Injection System"

21-3

RULES FOR CLEANLINESS WHEN WORKING ON TURBOCHARGER

- o Thoroughly clean all unions and surrounding areas before disconnecting.
- o Place removed parts on clean surface and cover with film or paper. Do not use fluffy cloths!
- o Carefully cover or seal opened components if repairs cannot be carried out immediately.
- o Only install clean parts.
 - Only unpack replacement parts immediately prior to installation.
 - Do not use parts that have been stored loose (e.g. in toolboxes etc.).

21-4

REMOVING AND INSTALLING TURBOCHARGER

o Always renew seals, gaskets and self-locking nuts.

- Disconnect earthing strap to battery.

Note:

On vehicles without fresh air filter or air conditioner, battery is located in plenum chamber on right. On vehicles with fresh air filter or air conditioner, it is installed under rear seat cushion.

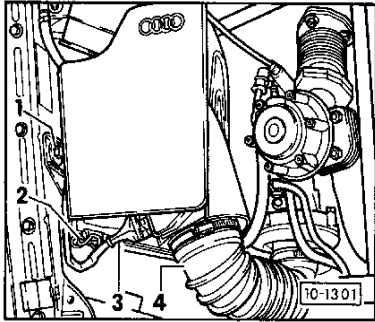

- ◀ - Remove air hose between air volume sensor and turbocharger -4- at air volume sensor.
- Pull connector off air volume sensor -3-.
- Unscrew retaining bolt -1-.
- Loosen four spring clips -2-.
- Take off upper section of air cleaner housing and filter insert.
- Disconnect intake hose and remove lower section of air cleaner housing.

21-5

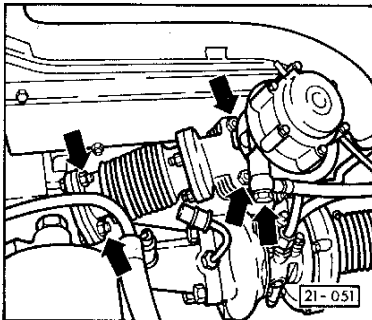

Removing waste gate:

- ◀ - Unscrew control pipe from waste gate.

Note:

Store banjo bolt so that it cannot become dirty or damaged.

- Unscrew corrugated pipe from exhaust pipe.
- Unscrew waste gate from exhaust manifold.

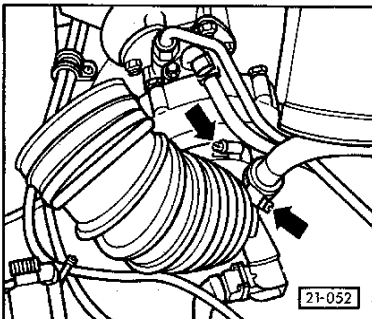

Removing turbocharger:

- ◀ - Unscrew hose between air volume sensor and turbocharger at turbocharger -arrow-.
- Unscrew crankcase ventilation pipe -arrow-.
- Pull off vacuum hose and hose to pressure pipe from overrun cut-off valve.

21-6

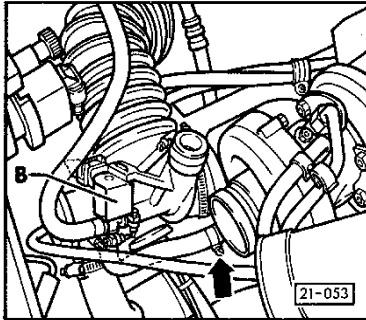

- ◀ - Pull solenoid valve for boost pressure limiting -B- out of bracket.
- Remove hose between solenoid valve for boost pressure limiting and turbocharger -arrow-.

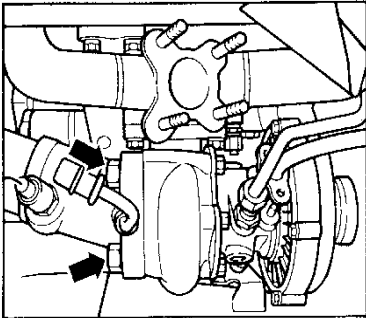

- ◀ - Unscrew four nuts on turbocharger/exhaust down pipe flange -arrows-.

Note:

- o To loosen lower rear nuts on turbocharger/exhaust down pipe flange, flat ring spanner (SW 15) must be bent to fit -arrow in lower diagram-.
- o Other nuts on turbocharger/exhaust down pipe flange are spanner size 17.

- Remove exhaust down pipe - see Repair Group 26.

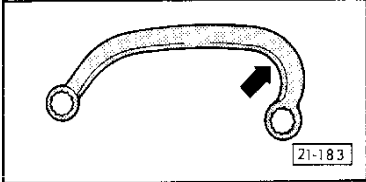

21-7

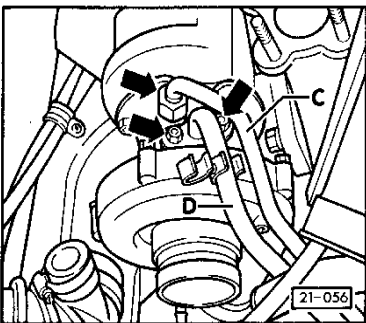

- Note:
- o After unscrewing coolant pipes these must be plugged immediately with suitable plugs.
 - o Make sure that no coolant reaches turbocharger oil passages.

- ◀ - Unscrew coolant supply pipe -C- and oil supply pipe -D- from turbocharger.

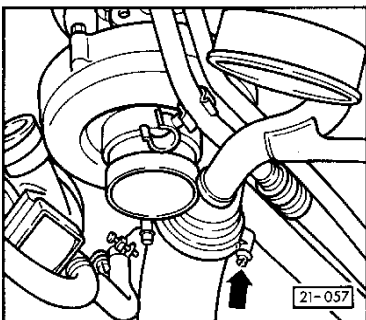

- ◀ - Unscrew hose from turbocharger to intercooler at turbocharger -arrow-.
- Unscrew oil return pipe at bottom of turbocharger.
- Unscrew coolant return pipe from turbocharger.

21-8

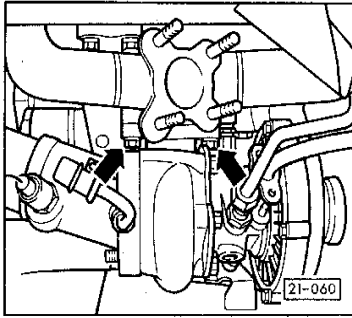

- ◀ - Unscrew turbocharger from exhaust manifold.

Installing:

- First screw turbocharger onto exhaust manifold.
- Connect to coolant lines to oil return pipe.
- Before screwing on oil supply pipe, fill oil passage on turbocharger with oil.
- Watch installation position of corrugated pipe - see Repair Group 26.
- Run engine at idle for approx. 1 minute after installing turbocharger. Do not rev up, as oil supply of turbocharger is not yet ensured.

21-9

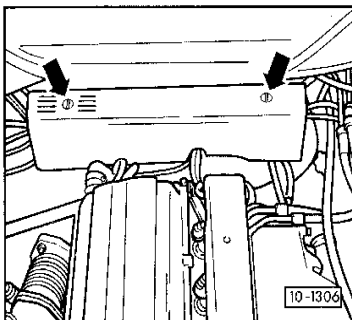

CHECKING TURBOCHARGER AND WASTE GATE

Test conditions

- o Interrogate fault memory - see Workshop Manual Audi 100 "Motronic Ignition and Injection System"
- o Carry out final control element diagnosis - see Workshop Manual Audi 100 "Motronic Ignition and Injection System"
- o Engine oil temperature at least 30 °C
- o No leaking vacuum connections

- ◀ - Turn quick fasteners -arrows- on connector cover on rear engine compartment bulkhead 90° to left and remove cover.

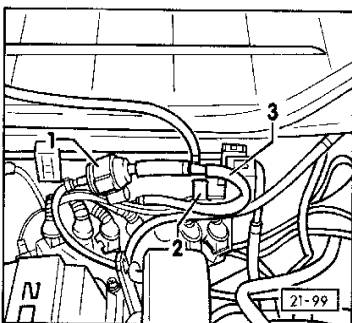

- ◀ - Disconnect moisture separator -1- from bracket -2- and pull off hose -3-.
- Fit T-piece with measuring hose of turbocharger tester between moisture separator -1- and disconnected hose.

21-10

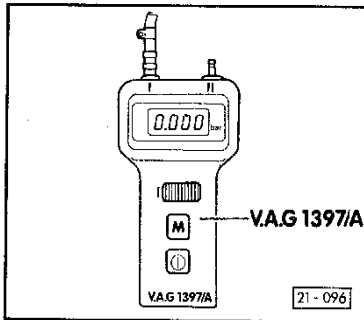

- Route measuring hose over rear edge of bonnet and through right window opening into vehicle interior.
- ◀ - Switch on turbocharger tester, switch measuring range switch to position -I- and attach measuring hose to union -I-.

Note:

- o Hoses must be connected absolutely leak-free, as otherwise measuring errors are possible.
- o By pressing memory button M on turbocharger tester, last measuring value is stored until memory button M is pressed again or tester is switched off.
- o Storage in memory is indicated by blinking of decimal point in display.
- o If battery voltage of turbocharger tester drops below permissible limit, arrow appears in upper left-hand corner of display.
- o Before checking, drive vehicle briskly for at least 3 km (no traffic lights etc.)
- o As boost pressure is measured during driving, second mechanic must be present to operate turbocharger tester for safety reasons.

21-11

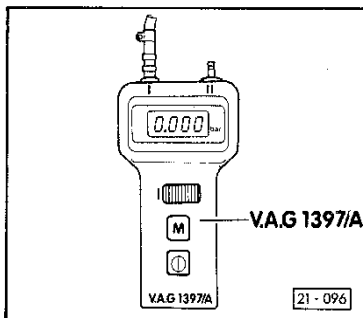

- Fully depress accelerator in 4th gear when road speed is approx. 60 km/h and observe rev. counter.
- ◀ - Press memory button M on turbocharger tester at 3000 rpm.

Specified value:

Altitude (m)	Outside temperature	Boost pressure (bar)
0 - 1600	0°	1.840 - 2.000
0 - 1600	20°	1.990 - 2.100
0 - 1600	30°	2.030 - 2.150

0 = Sea level

For intermediate values of outside temperature, boost pressure values may deviate slightly.

- If specified value is obtained, but poor performance is noticed in speed range below 2500 rpm, check overrun cut-off valve - Page 21-13.
- If specified value is not obtained, temporarily renew waste gate and repeat check.
- If specified value is still not obtained, renew turbocharger.

21-12

CHECKING OVERRUN CUT-OFF VALVE WITH VACUUM PUMP V.A.G 1390

- o Overrun cut-off valve is located in front of turbocharger. It opens overrun phase with vacuum pressure, thus relieving existing boost pressure in front of throttle valve in order to prevent load shock during acceleration/deceleration changes.
- o If performance is down or shock loads occur during load changes, overrun cut-off valve must be checked.

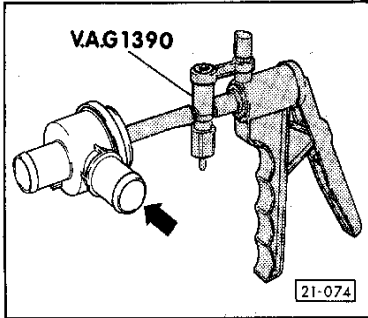

- ◀ - Attach vacuum pump V.A.G-1390 to overrun cut-off valve.
- Operate vacuum pump.
 - o Overrun cut-off valve must open -arrow-.
- After approx. 30 seconds, operate venting valve of vacuum pump.
 - o Overrun cut-off valve must close -arrow-.
- If overrun cut-off valve does not open or close, or if valve plate is leaking with cut-off closed, renew valve. Secure connections of overrun cut-off valve with hose clips.

21-13

REMOVING AND INSTALLING INTERCOOLER COMPONENTS

Note:
All hose connections are secured with clips.

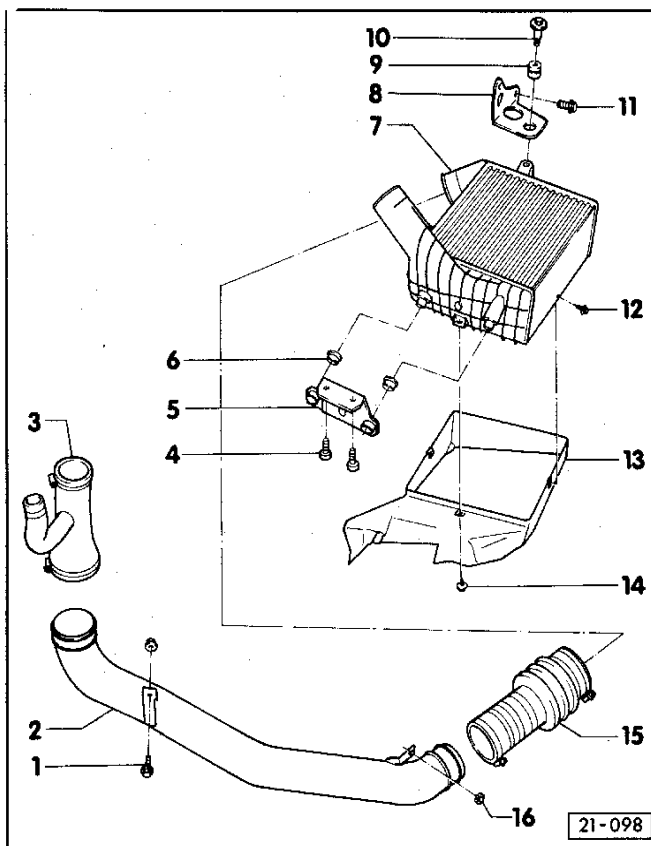

- 1- 20 Nm
- 2- Pressure pipe
- 3- Air hose
 - o To turbocharger
 - o With branch to overrun cut-off valve
- 4- 20 Nm
- 5- Front angle bracket
- 6- Rubber grommet
 - o For front angle bracket
- 7- Intercooler
- 8- Rear angle bracket
- 9- Rubber grommet
 - o For rear angle bracket
- 10- Cheese-head bolt with collar
 - o 20 Nm

21-14

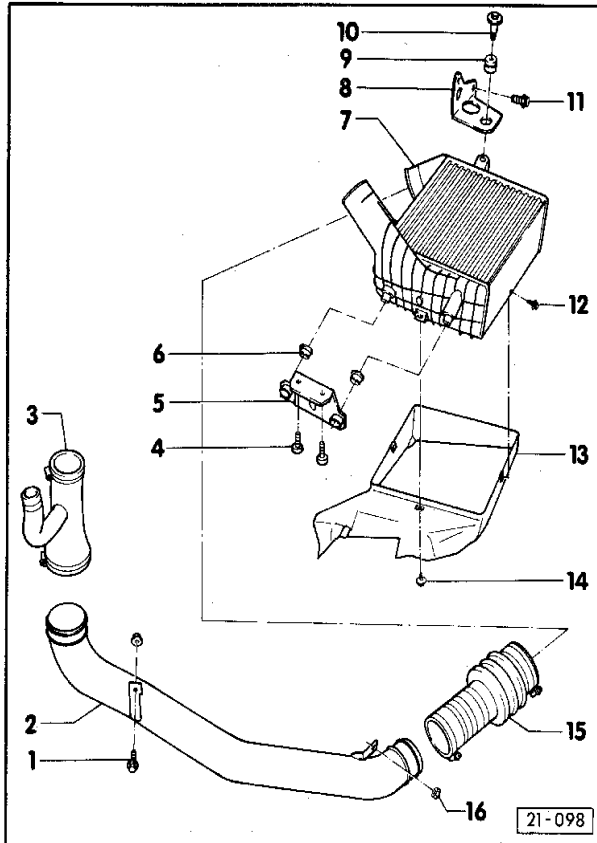

- 11- 20 Nm
- 12- Self-tapping screw
o For securing air guide
- 13- Air guide
- 14- Self-tapping screw
o For securing air guide
- 15- Air hose
o To intercooler
- 16- 20 Nm

21-15

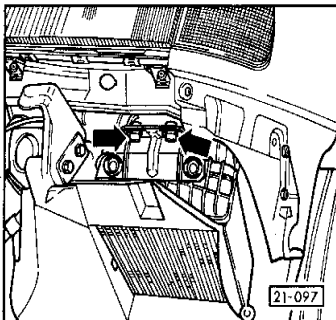

REMOVING AND INSTALLING INTERCOOLER

- Remove front bumper - see Workshop Manual Audi 100 "General Body Repairs", Repair Group 63.
- Unscrew reservoir for hydraulic fluid from engine compartment sidewall and put aside with lines connected.
- Unscrew windscreen washer water reservoir.
- Disconnect two air hoses at intercooler.
- ◀ - Remove bolts from front bracket -arrows-.
- Unscrew rear securing bolt from intercooler.
- Take off intercooler downward.

21-16

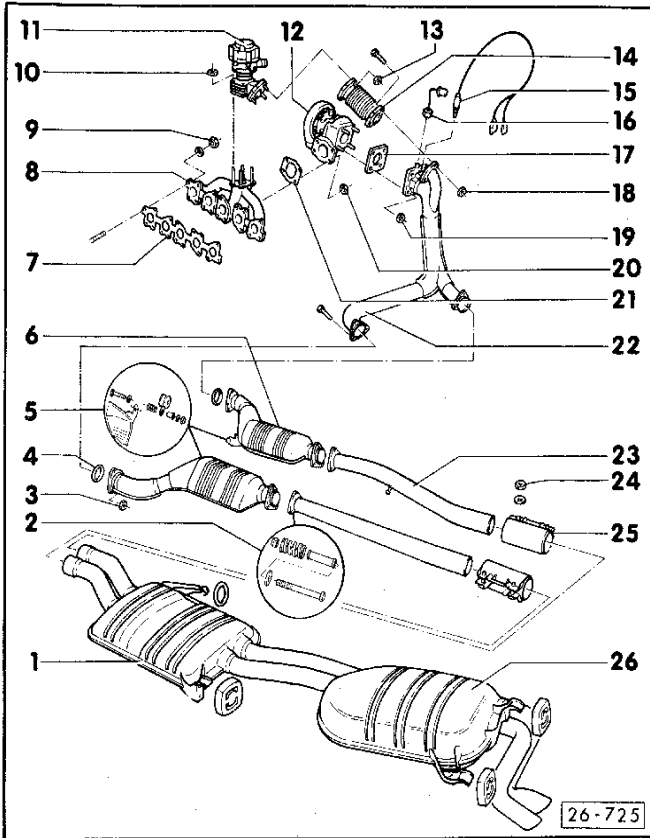

REMOVING AND INSTALLING EXHAUST SYSTEM COMPONENTS

Note:

- o Renew gaskets, seals and self-locking nuts.
- o Install retaining rings and bands in accordance with parts list
- o Ensure sufficient space between exhaust system and body.
- o Align exhaust system tension-free - Page 26-7.

- 1- **Main silencer**
 - o Combined with rear silencer to form one unit
 - o Separating point is provided for renewing individual silencer - Fig. 5, Page 26-6
- 2- **25 Nm**
 - o Parts arrangement - Fig. 1, Page 26-4
- 3- **25 Nm**
- 4- **Sealing ring**
 - o Sensitive to impact - do not drop

26-1

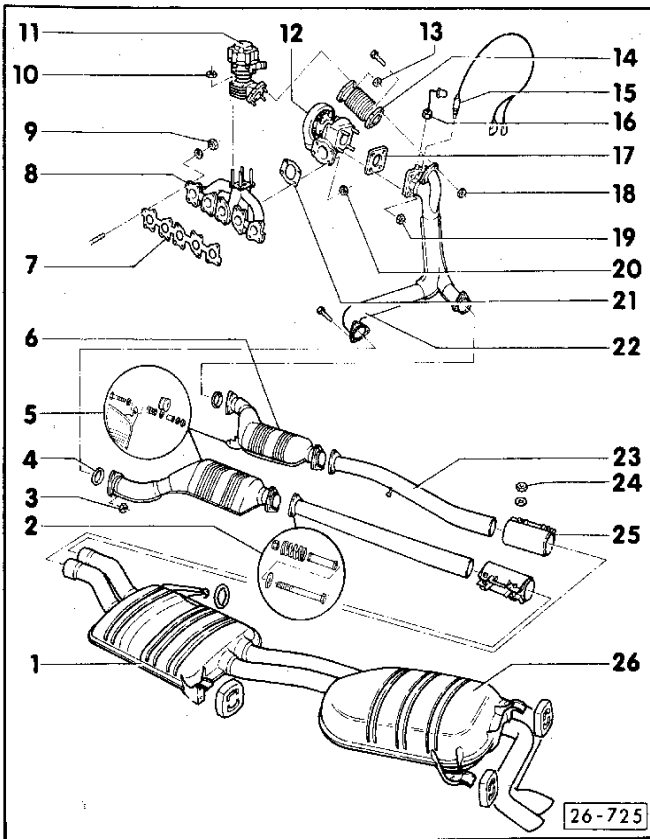

- 5- **25 Nm**
 - o Arrangement of parts - Fig. 2, Page 26-4
- 6- **Catalyst**
- 7- **Exhaust manifold gasket**
 - o Flanged surface must face exhaust manifold
 - o Renew
- 8- **Exhaust manifold**
 - o To remove, remove turbocharger - see Repair Group 21
- 9- **25 Nm**
 - o Renew
- 10- **25 Nm**
 - o Renew
- 11- **Waste gate**
 - o Removing - see Repair Group 21
- 12- **Turbocharger**
 - o Removing - see Repair Group 21
- 13- **25 Nm**
 - o Renew
- 14- **Corrugated pipe**
 - o Installation position - Fig. 4, Page 26-5

26-2

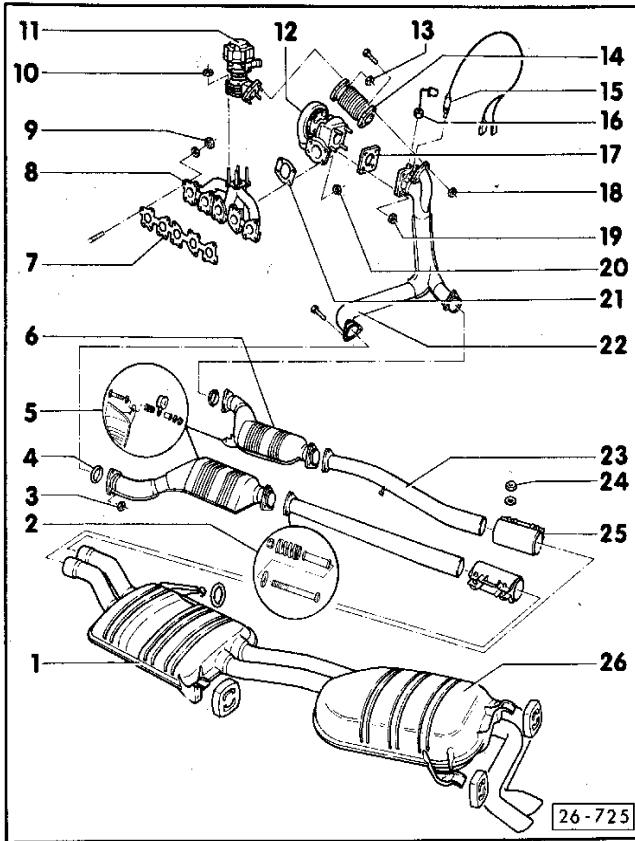

- 15- Lambda probe
o 50 Nm
- 16- CO measuring tube
o 20 Nm
- 17- Gasket
o Renew
- 18- 25 Nm
o Renew
- 19- 30 Nm
o Renew
- 20- 60 Nm
o Renew
- 21- Gasket
o Renew
- 22- Exhaust down pipe
- 23- Centre exhaust pipe
- 24- 40 Nm
- 25- Double pipe clamp
o Renew after unscrewing one bolt
o Installation position - Fig. 6, Page 26-5
- 26- Rear silencer
o Combined with main silencer to form one unit
o Separating point is provided for renewing individual silencer - Fig. 5, Page 26-6

26-3

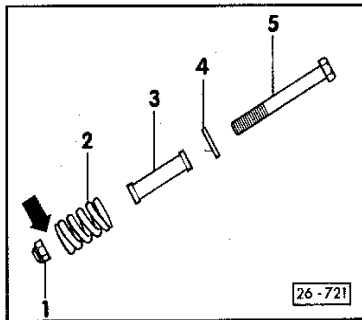

◀ Fig. 1 Centre catalyst/exhaust pipe fastener

- o Arrangement of parts:
- 1- Nut (25 Nm)
- Arrow - Flange position
- 2- Spring
- 3- Sleeve
- 4- Washer
- 5- Bolt

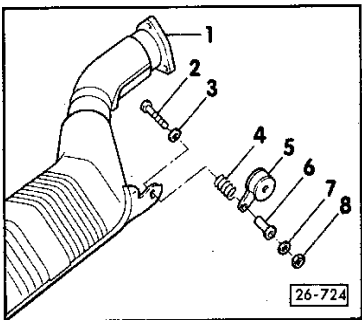

◀ Fig. 2 Bracket

- o Arrangement of parts
- 1- Catalyst
- 2- Bolt
- 3- Washer
- 4- Spring
- 5- Bracket
- 6- Sleeve with shoulder
- 7- Washer
- 8- Nut

26-4

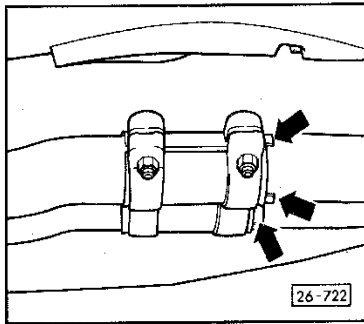

◀ Fig. 3 Double pipe clamp

- o Installation position:
Pipe clamp must contact stop tabs -arrows-.

Note:
Renew double pipe clamp each time fastener is loosened.

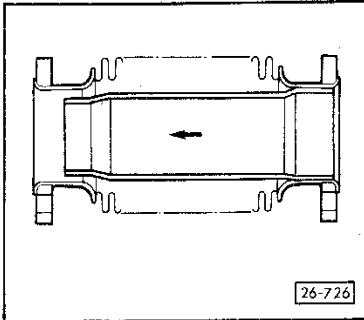

◀ Fig. 4 Corrugated pipe

- o Installation position:
Direction of flow -arrow- from exhaust manifold to exhaust system.

26-5

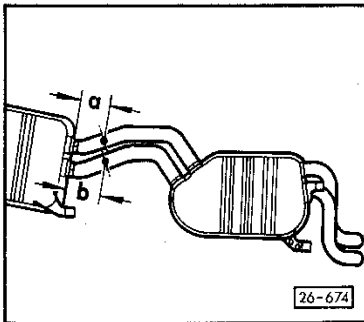

◀ Fig. 5 Separating point between main and rear silencer

Separating point is provided for renewing main or rear silencer.

Dimension a = 130 mm
Dimension b = 130 mm

26-6

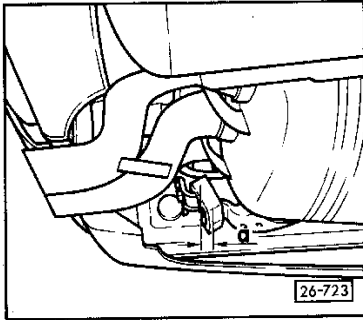

ALIGNING EXHAUST SYSTEM TENSION-FREE

- o Exhaust system is aligned while cold.
- Ensure sufficient clearance between all parts of exhaust system and body.
- ◀ - When exhaust system is correctly fitted, pretension at rear mounts of rear silencer must be -a- = approx. 10 mm.

26-7

CHECKING EXHAUST SYSTEM FOR LEAKS

Leaks in exhaust system upstream of Lambda probe may lead to following malfunctions:

- o Starting problems
- o Engine stalling
- o Shaking at idle
- o Uneven acceleration
- o Poor progression

Test conditions:

- o Engine cold or hand warm
- o Do not run engine
- Insert compressed air gun into one exhaust system tailpipe and seal with rag.
- Also seal second tailpipe with rag.
- Set operating pressure of compressed air system to approx. 6 bar.
- Operate compressed air gun continuously.
- Spray connection points of cylinder head, manifold, manifold/exhaust pipe, exhaust pipe/catalyst, connection points behind catalyst etc. with leak detection spray (commercially available) and watch for bubbles.
- Repair any leaks found.
- Only use sealing compound in special cases.

26-8